

WHITE PAPER

# Engineer's Guide to 5G Semiconductor Test

## Five Challenges of 5G Wideband Test

### CONTENTS

Introduction.....	3
I. Working With More Complex, Wideband Waveforms.....	4
NI Solution.....	5
II. Configuring Wideband Test Benches for Extensive Frequency Coverage ....	7
NI Solution.....	8
Extended Frequency Coverage to mmWave With the PXIe-5831 mmWave Vector Signal Transceiver.....	8
III. Characterizing and Validating 5G Components .....	10
Coexistence With Other Standards and Technologies .....	10
TX/RX Reciprocity .....	10
Testing Multiband Devices .....	11
Envelope Tracking.....	12
New Device Types for mmWave Operation .....	13
RF-to-RF Beamformers .....	13
IF-to-RF Beamformers.....	14

Digital Control Challenge .....	16
NI Solution.....	16
IV. Testing Massive MIMO and Beamforming Over the Air .....	19
OTA for More Accurate Characterization .....	20
Far-Field Measurement Challenges .....	20
Thermal Test Challenges .....	22
Spatial Scanning Test Challenges .....	23
OTA Calibration Procedure.....	24
3D Radiation Pattern .....	24
Radiated Power and Modulated Tests .....	24
Receiver Tests.....	25
Fine Spatial Grids and Test Time Challenges .....	25
mmWave Measurement-Uncertainty Challenges .....	27
Measurement Equipment Challenges.....	28
RF Chamber Measurement Challenges.....	28
Positioning Measurement Challenges .....	30
Antenna Measurement Challenges .....	31
Procedural Measurement Challenges .....	32
NI Solution.....	33
Faster Test Speeds Through Hardware-Timed Motion Control .....	33
V. Transitioning to High-Volume 5G Device Production .....	34
NI Solution.....	36
Conclusion .....	37
References.....	37

## Introduction

A few years ago, in 2016, [researchers at Nokia Networks](#) were paving the way for next-generation wireless communications by working with NI to investigate mobile access in the mmWave frequency spectrum. As part of this broad collaboration, NI and Nokia Networks jointly developed one of the first mmWave communication links capable of streaming data at speeds exceeding 10 Gb/s—the fastest mobile access wireless system ever publicly demonstrated. Achieving 10 Gb/s data rates in the mmWave spectrum required a design environment based on NI software defined radio hardware for the rapid prototyping key to this proof of concept.

Around that time, engineers and [researchers at the University of Bristol](#) and Lund University used the NI MIMO Prototyping System to rapidly innovate and advance 5G cellular networks, seeking to address the unprecedented demand for increased data rates, expanded network capacity, and improved 5G network reliability. The team successfully demonstrated greater than 20X increases in bandwidth efficiency compared to current 4G cellular technologies—opening new, record-setting realms of possibility for 5G deployment in sub-6 GHz bands.

About a year later, also relying on NI's flexible hardware and software platform, [AT&T developed a new type of real-time channel sounder](#) that it is currently using to create highly advanced models to give mobile customers the best possible connectivity experience. This system eliminates the need to repeat experiments or adjust equipment to take multiple measurements from one location. Because parameter extraction is done in real time, the integrity of the collected data can be evaluated in real time for 5G mmWave frequency measurement via drive testing. As the 5G ecosystem expands to include such use cases as assisted driving, connected car, self-driving cars, and more, it becomes increasingly critical to study and model vehicular channels.

These research activities and countless others, along with 3GPP's consistent work to craft and publish an ambitious and disruptive 5G specification, have brought the wireless industry to the present. Moving beyond the labs, 5G device and equipment manufacturers find themselves looking for fast and cost-effective ways to fabricate and test while anticipating enormous market demands.

This paper assumes a basic [familiarity with the 5G physical layer](#); it focuses on the new challenges of testing semiconductor devices for wideband 5G applications. The enhanced mobile broadband (eMBB) use case points to supporting greater user data rates and increased system capacity. Departing from legacy 3G and 4G cellular standards, eMBB introduces radically higher operating frequency bands, deploying not only in traditional cellular bands but also higher frequencies to 3.5 GHz, 6 GHz, and up to the mmWave range, for much higher bandwidth allocations. Furthermore, 5G technology also relies on beamforming and Massive MIMO technology to increase spectral efficiency. This requires advanced antenna arrays composed of tens or even hundreds of transmitter (TX)/radio receiver (RX) antenna elements.

## I. Working With More Complex, Wideband Waveforms

The 3GPP 5G New Radio specification includes two types of approved orthogonal frequency-division multiplexing (OFDM) operation, various modulation and coding sets, flexible numerology, and several channel bandwidths. In addition to these parameters, 5G waveforms incorporate reference signals for channel estimation, better MIMO operation, and oscillator phase noise compensation. 5G waveforms introduce a self-contained integrated subframe design with uplink/downlink scheduling information, data, and acknowledgment in the same subframe.

5G base stations and other infrastructure devices, denoted as gNode B (gNB), use cyclic prefix OFDM (CP-OFDM) for downlink, whereas user equipment (UE) can operate with both CP-OFDM and discrete Fourier transform spread OFDM (DFT-s-OFDM), depending on which of the two schemes the gNB instructs the UE to use for uplink. DFT-s-OFDM helps improve the power amplifier efficiency and energy usage because it has lower peak-to-average power ratio (PAPR). Furthermore, the 5G standard specifies operation at two different basic frequency ranges (see Table 1) to account for the differences in propagation and reflection behavior of signals in the mmWave range versus those below 10 GHz. In many cases, the requirements throughout the RF specifications vary for the two different frequency ranges. Signals in the lower frequency range (FR1) can use frequency-division duplexing and time-division duplexing (TDD), taking up to 100 MHz of bandwidth, with carrier aggregation up to 400 MHz. However, FR2 signals up to 52.6 GHz only operate in TDD mode and have single-channel bandwidths of up to 400 MHz. They also can combine multiple carriers for aggregated bandwidths up to 800 MHz. This aggregated bandwidth could soon grow to specifications above 1 GHz.

Frequency Range	Rel. 15 Specification
FR1	450 MHz to 7.125 GHz
FR2	24.25 GHz to 52.6 GHz

Table 1. New Radio Frequency Ranges

All of these factors significantly increase the complexity of the waveforms with which researchers and engineers must work. They have the new challenges of creating, distributing, and generating standard-compliant uplink and downlink signals that have more configurations and options, and larger bandwidths, than ever before.

Multiplexing	Modulation	Numerology	Channel Width
CP-OFDM	Quadrature Phase Shift Keying (QPSK), 16-Quadrature Amplitude Modulation (QAM), 64-QAM, 256-QAM	Subcarrier Spacing: 15 kHz, 30 kHz, 60 kHz, 120 kHz, 240 kHz 10 ms Frame, 1 ms Subframe,	FR1: 5, 10, 15, 20, 25, 30, 40, 50, 60, 70, 80, 90, 100 MHz
DFT-s-OFDM	$\pi/2$ -Binary Phase Shift Keying, 16-QAM, 64-QAM, 256-QAM	14 Symbols per Slot (number of slots depends on subcarrier spacing)	FR2: 50, 100, 200, 400 MHz

Table 2. Various PHY Configurations for Wideband 5G Waveforms

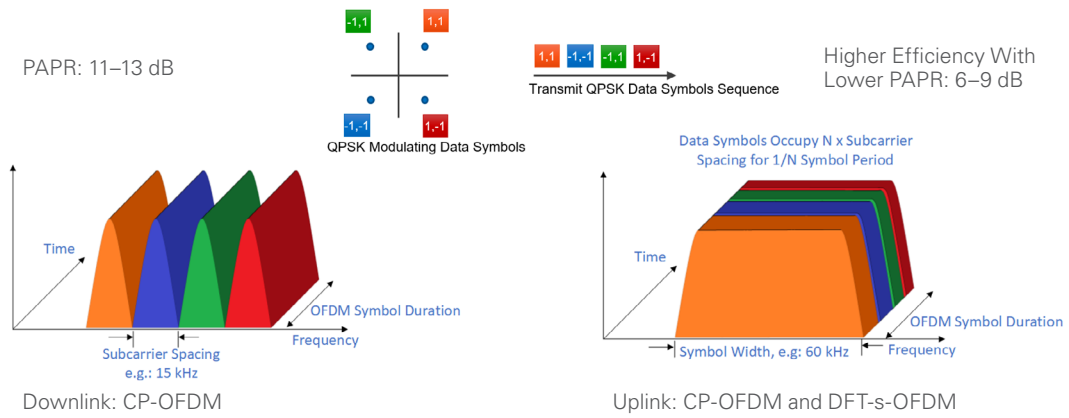

Figure 1. Downlink and Uplink OFDM Operation for 5G Waveforms

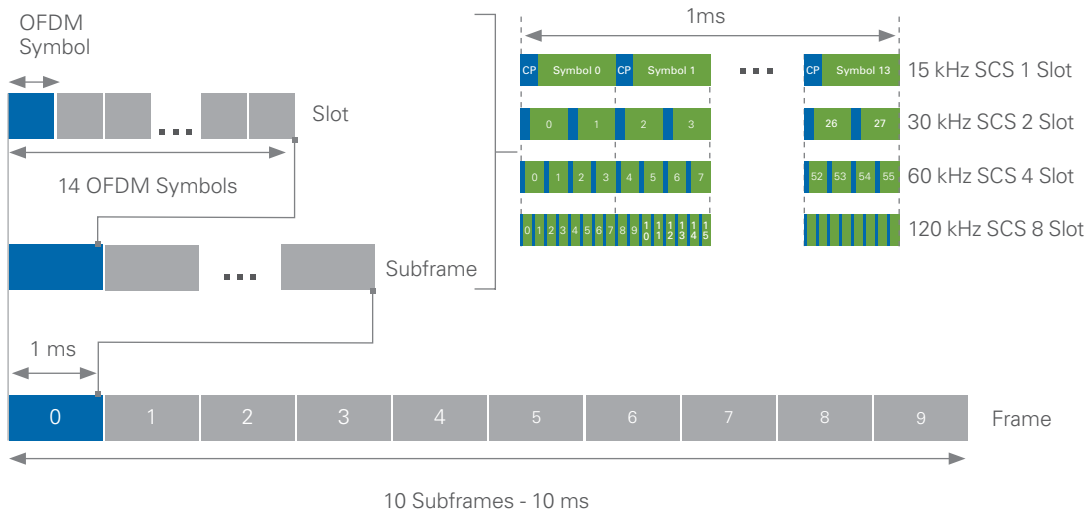

Figure 2. Flexible 5G Numerology

### NI Solution

To simplify the process of creating multiple 5G waveform combinations that engineers need to validate device performance, NI developed NI-RFmx Waveform Creator. This unified software environment for creating and playing back waveforms for wireless standards, including the latest New Radio specifications, can generate waveforms interactively on NI PXI instrumentation or create unlocked, unencrypted I/Q waveform files for playback in automated test sequences. Users can select CP-OFDM or DFT-s-OFDM operation, configure channel widths, switch modulation schemes, and add I/Q impairments.

Users also can create wireless local area network (WLAN), Bluetooth, and 2G to 4G and 5G waveforms to test for coexistence, picking from a wide range of predefined configurations for each standard and configuring detailed waveform parameters including multicarrier, filtering, and impairments. Users also can save their configurations and files and distribute them to multiple benches to ensure consistent test throughout their labs.

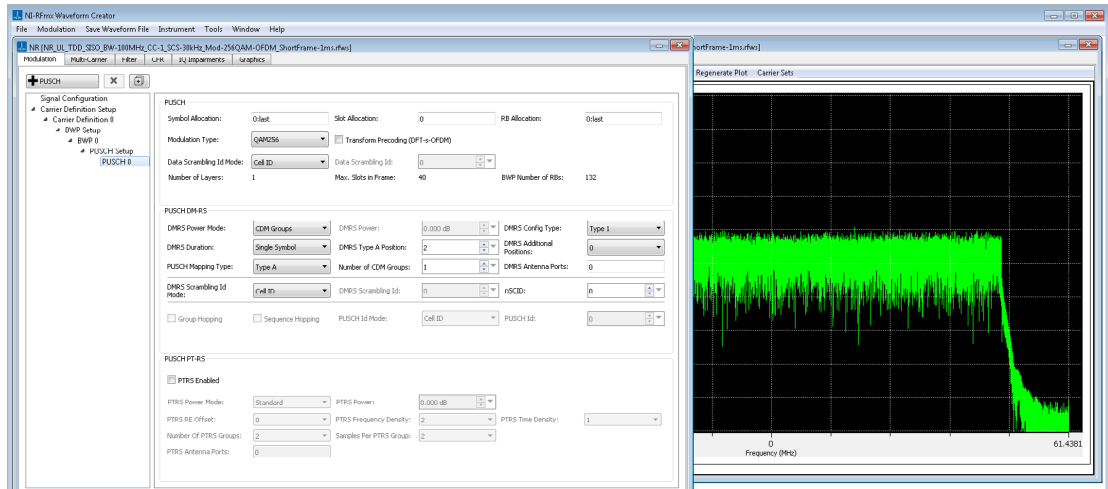

Figure 3. NI-RFmx Waveform Creator for Producing New Radio Waveforms With Ease

In addition to NI-RFmx Waveform Creator, NI offers the NI-RFmx analysis driver and APIs. These highly optimized APIs perform physical layer (PHY) RF measurements of wireless standards including LTE-A and New Radio. They give engineers simple access to the most advanced optimization techniques such as multimeasurement parallelism and multi-DUT measurements. The result is fast, pipelined measurement automation for reliable, high-quality tests of modulation accuracy, frequency error, adjacent channel leakage ratio (ACLR), channel power, occupied bandwidth, spectral emissions, IMD, and other spectral characteristics of signals with minimal software development efforts.

Visualizing these RF measurements becomes simple, thanks to a familiar and intuitive interactive experience with the NI-RFmx Soft Front Panel (SFP). Users can save and load their SFP configurations and apply them to their automation code. They also can pause test execution and take control of automated test code from the SFP interface for quick debugging and troubleshooting. Finally, users can select and visualize active automated measurements to monitor their test execution.

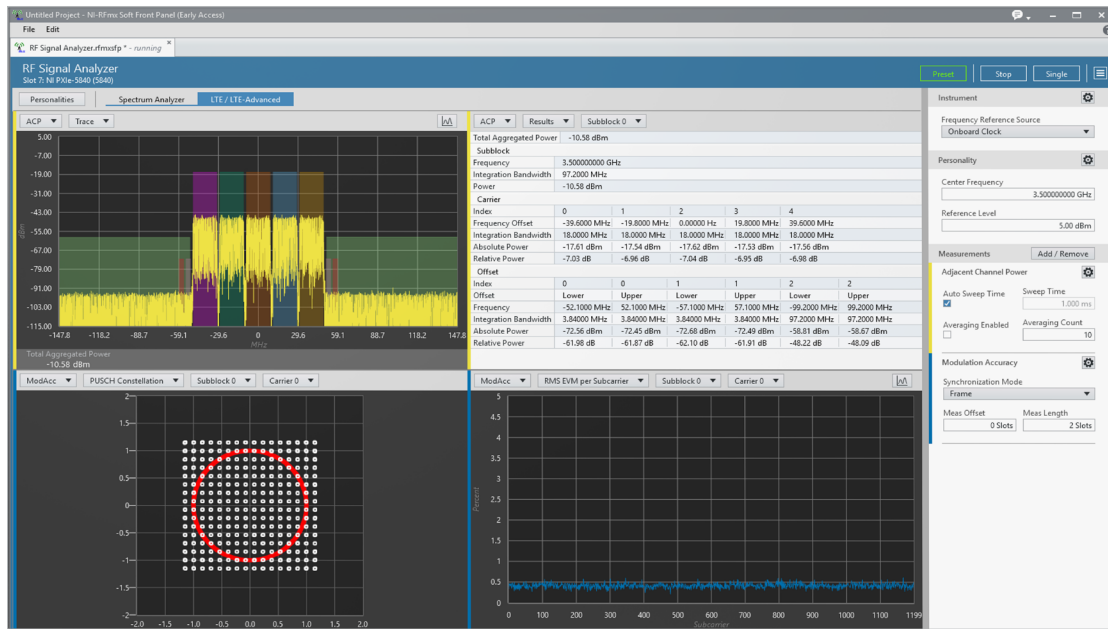

Figure 4. NI-RFmx SFP for Ease of Bring-Up, Configuration, Debugging, and Live Monitoring

## II. Configuring Wideband Test Benches for Extensive Frequency Coverage

To achieve some of the ambitious key performance indicators of 5G enhanced mobile broadband—surpassing 20 Gb/s in downlink and supporting 10,000X more traffic—the 5G standard specifies wideband operation at two different basic frequency ranges, with varying channel bandwidths. It seeks to reuse many existing and some new cellular and unlicensed bands from around 400 MHz up to 7.125 GHz (FR1) and from 24 GHz to 52.6 GHz (mmWave FR2).

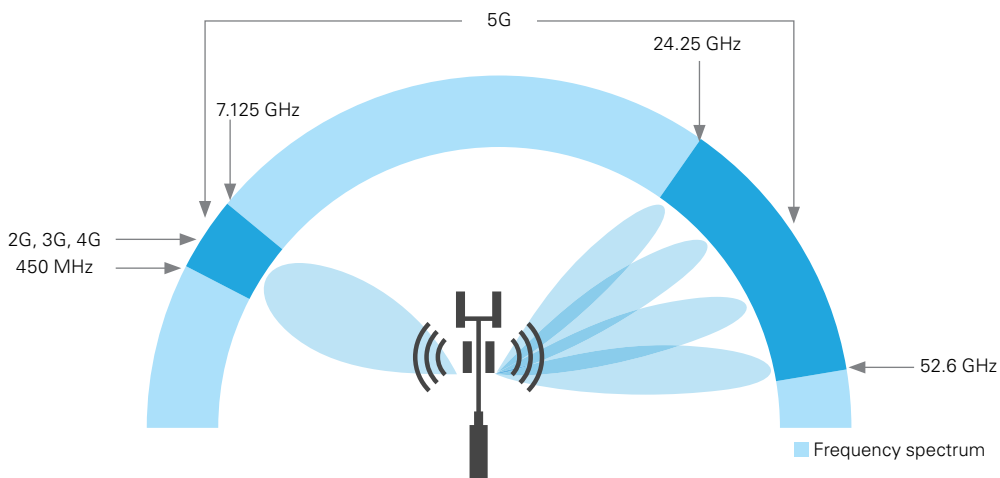

Figure 5. Frequency Ranges for 5G New Radio

Although RF engineers have been working with specialized and expensive test systems for mmWave in industries such as aerospace and military, this represents unexplored territory for the mass-market cellular industry. Building more effective validation benches is a challenge for

test engineers because of diverse new devices and unknown, undefined future requirements. A traditional approach to 5G devices, including the latest mmWave components, requires a collection of large, expensive box instruments designed for manual test execution. Engineers face the challenge of integrating, scaling, and optimizing their setups for automated device validation. They need to configure a greater number of test benches for new device types with cost-effective test equipment that provides high linearity; tight amplitude and phase accuracy over very large bandwidths; low phase noise; extensive frequency coverage for multiband devices; and the ability to test for coexistence with other wireless standards. To adapt to rapidly evolving test requirements, they need modular, software-based test and measurement benches with large frequency coverage.

### **NI Solution**

The PXI Vector Signal Transceiver (VST) combines an RF and baseband vector signal analyzer and generator with 1 GHz of instantaneous RF or complex I/Q bandwidth. The VST incorporates the fast measurement speed and small form factor of a production test box with the flexibility and high performance of an R&D-grade box instrument. Utilizing their large bandwidth, VSTs readily can power 5G test benches and cover a variety of challenging test cases, including digital predistortion of carrier-aggregated 5G waveforms, as well as intraband and interband coexistence of 4G and 5G. In addition, thanks to the subnanosecond synchronization of the PXI platform, test benches easily can include additional VSTs to support MIMO configurations. The combination of low phase noise, high linearity, and patented I/Q calibration means that the VSTs can measure excellent error vector magnitude (EVM) performance with higher order modulation schemes such as 256-QAM on the narrowest 5G subcarrier spacing.

### **Extended Frequency Coverage to mmWave With the PXIe-5831 mmWave Vector Signal Transceiver**

Engineers in charge of test benches for 5G mmWave devices can benefit from the high-performance capabilities of the VST up to the 5G mmWave frequency range (FR2) with the mmWave VST. The mmWave VST uses the proven VST architecture to deliver higher measurement speed and mmWave performance at an attractive price point.



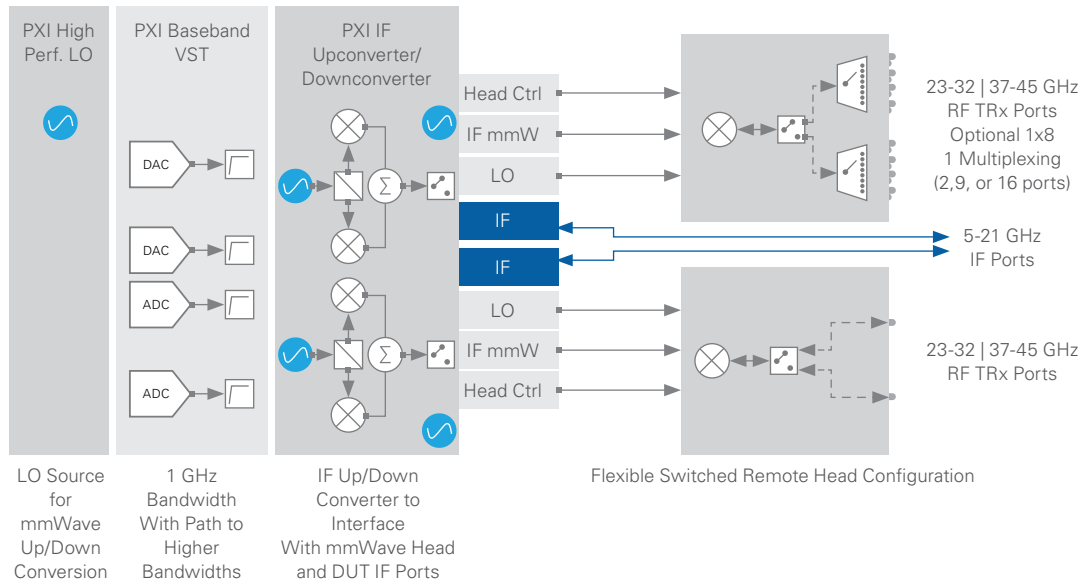

Figure 6. mmWave VST Block Diagram

The mmWave VST supports a wide range of frequencies and can test at IF (5-21 GHz) and RF (23-44 GHz) with a single instrument, giving engineers the flexibility to interface with many new types of DUTs and test emerging technologies with a single system. Every mmWave VST supports integrated, calibrated switching to expand port count without significant capital investment or increased system complexity, while multiple mmWave VSTs can be integrated in a single PXI system to further increase bench capabilities for emerging technologies such as MIMO and phased arrays.

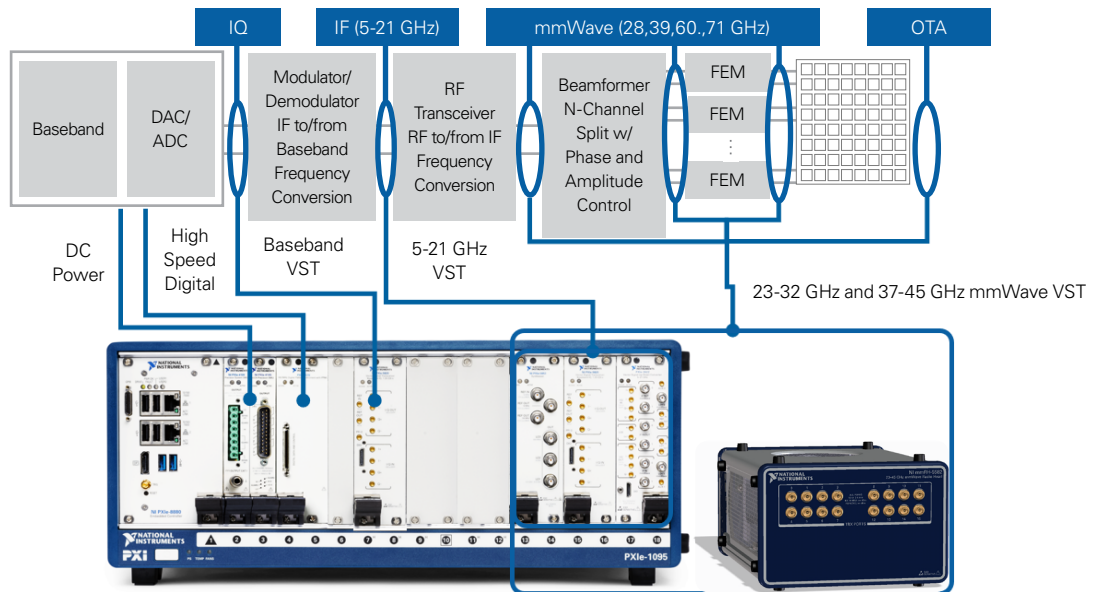

Figure 7. 5G Test Bench With mmWave VST. for mmWave Applications

### III. Characterizing and Validating 5G Components

#### Coexistence With Other Standards and Technologies

Initial deployments of 5G will likely use Non-Standalone mode (NSA), in which UE will rely on the LTE network for link control and some data, and use the 5G connection as a high-bandwidth data pipe. As a result, engineers need to verify the coexistence of 5G New Radio (NR) with LTE both in-band and in adjacent bands. The 5G system will enable bandwidth parts to share a carrier for the 5G and LTE signals, forcing engineers to validate the performance of their devices with closely spaced signals.

Future releases of the NR specification will integrate license-assisted access (LAA) through unlicensed spectrum, which serves as an aggregated secondary channel. This means that engineers must test the effect of their devices on specific unlicensed bands for proper coexistence.

Similarly, when a UE incorporates multiple radio transceivers for various standards, engineers must pay additional attention to their filtering and interference-avoidance designs for in-band and out-of-band signals to ensure in-device coexistence. Harmonics, non-linear spectral regrowth, and various spurs from one standard can affect the sensitivity of 5G NR devices.

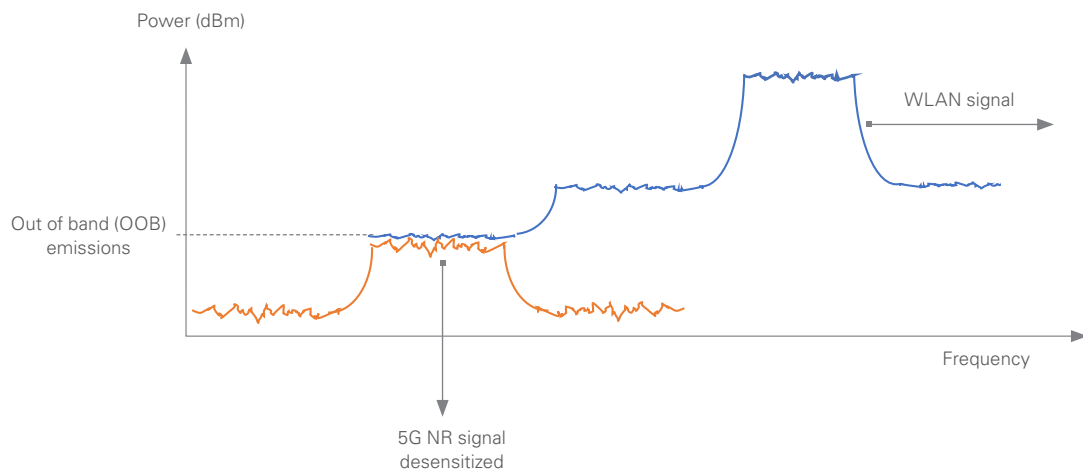

Figure 8. Desensitization of 5G NR due to WLAN out of band leakage.

#### TX/RX Reciprocity

Another critical factor facing engineers working on transmit/receive systems is trying to improve the reciprocity between the TX and RX paths. For example, as the system drives the transmit power amplifiers (PAs) well into compression, the PAs introduce amplitude and phase shifts (AM-AM and AM-PM response) and other thermal effects to a larger extent than the low-noise amplifier (LNA) in the receiver path would produce. Additionally, the tolerances of phase shifters, variable attenuators, gain control amplifiers, and other devices could cause unequal phase shifts between channels, affecting the system's anticipated phase coherency.

Characterizing greater performance out of RF communications components, such as front-end modules (PAs and LNAs), duplexers, mixers, and filters, presents a new set of

measurement challenges. On the quest for greater energy efficiency and linearity across larger bandwidths, 5G PAs rely on linearization techniques, such as digital predistortion (DPD). AM-AM and AM-PM plots give some insight into the behavior of the PAs, but designers need to consider the larger memory effects of very wide 5G signals. Because circuit models have difficulty predicting memory effects, the only practical way to deal with them is to test the PA and capture the time-domain signal after it passes through the DUT. Established DPD techniques require test equipment to generate and measure at 3-5X the signal bandwidth. This represents a real challenge for test equipment needing to predistort 5G signals occupying 100, 200, and 400 MHz of bandwidth.

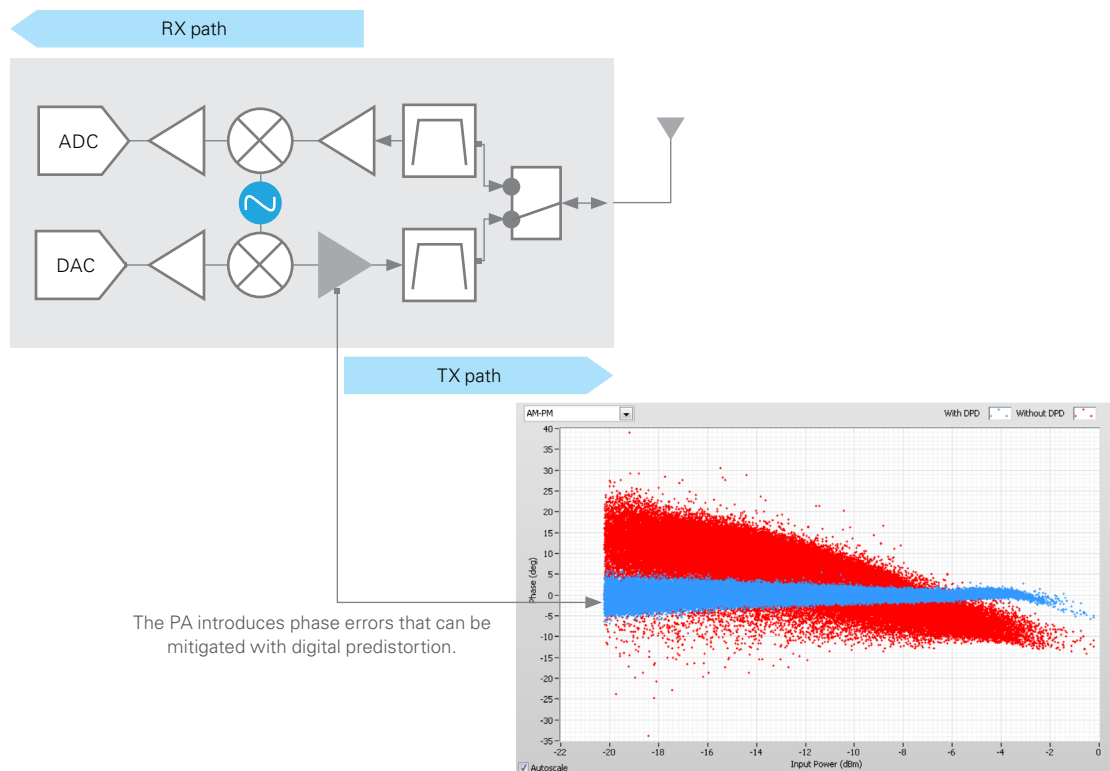

Figure 9. Characterizing Transmitter and Receiver Reciprocity

## Testing Multiband Devices

The difficulty of characterizing and testing these components increases as the industry evolves to serve market needs with multiband front-end modules (FEMs) and power amplifier modules with integrated duplexer PAMiDs. These devices require multichannel test benches that can switch quickly to test the performance of each path and band combination, occasionally testing in parallel. Additionally, typical test plans involve complete sweeps over power supply voltage levels; variations in loading conditions; output power levels, linearity, and modulation accuracy with and without DPD; band combinations; and temperature.

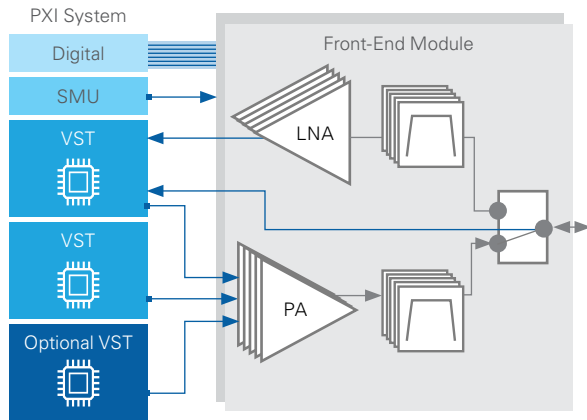

Figure 10. Multichannel Front-End Module Test Setup With VSTs

Many of these multiband devices must support Evolved Universal Terrestrial Radio Access New Radio Dual Connectivity (EN-DC), involving simultaneous operation of 4G and 5G standards. As a result, engineers must cover an ever-growing number of test cases involving multiple combinations of single carrier and carrier-aggregated signals. These take place not only below 6 GHz, but now also around 7 GHz to account for New Radio unlicensed operation (NR-U) in new open bands. Because of the higher device integration and component density, characterizing thermal management and heat dissipation of these devices when transmitting LTE and NR signals becomes critical.

NUMBER OF CARRIER-AGGREGATED COMBINATIONS PER 3GPP RELEASE (ORDER OF MAGNITUDE)

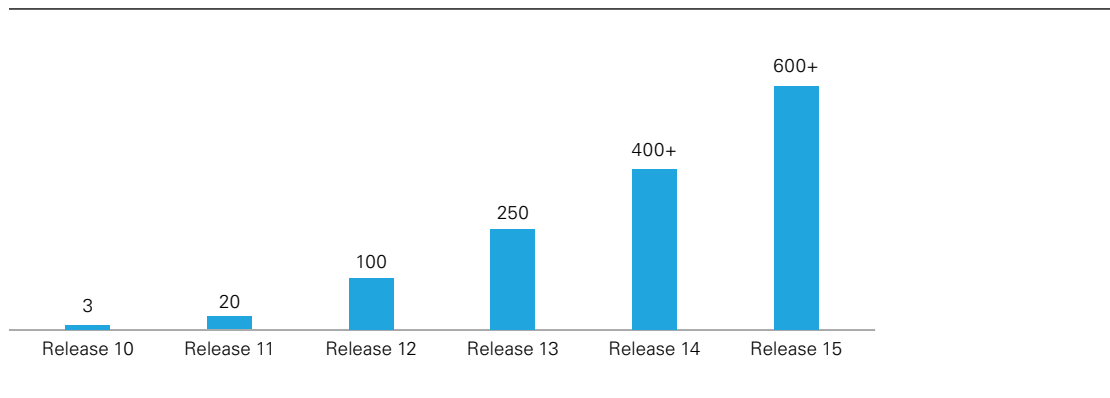

Figure 11. The Number of Test Cases for FEMs Continues to Grow With NR

## Envelope Tracking

Engineers working on efficient 5G front ends need to test the envelope-tracking capabilities of their devices for 5G channel bandwidths, especially at or above 100 MHz. Extending envelope-tracking technology to the 100 MHz uplink bandwidth and 256-QAM modulation needed for 5G NR may seem like an impossibility because the test benches must be able to trigger and generate very wide baseband envelope signals near perfectly time-aligned with larger and more complex waveforms. However, engineers strive to achieve this level of performance

to increase the power efficiency and battery life of their devices to satisfy user demands. Furthermore, they know that front ends that implement accurate envelope tracking help improve 5G network coverage and capacity, which are vital metrics for network operators.

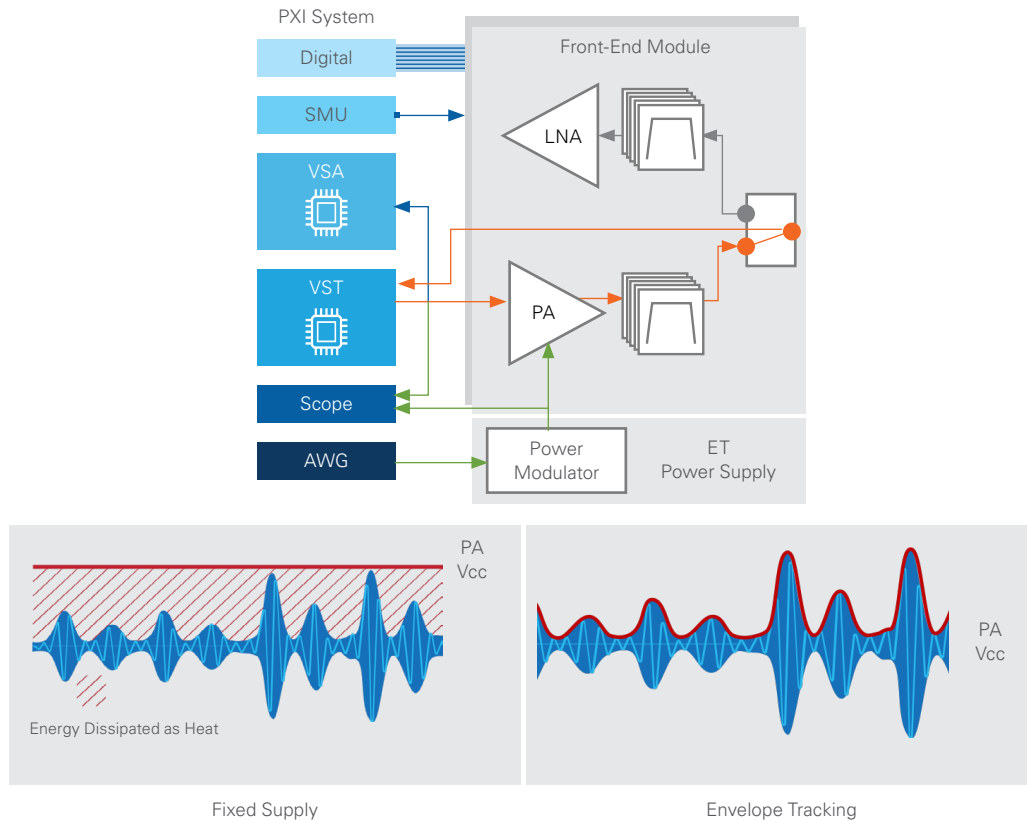

Figure 12. Envelope-Tracking Test-Setup Diagram

## New Device Types for mmWave Operation

To overcome significant propagation losses, 5G requires beamforming subsystems and antenna arrays. Testing new beamforming ICs demands fast and reliable multiport test solutions. These solutions must test the signal gain and phase control of every path to ensure proper level tapering and phase adjustment for sidelobe reduction and beam steering in the right direction. However, as designs move up in frequency towards the mmWave range, the system phase noise from local oscillators gets multiplied and tends to dominate, introducing test challenges for component testing. Test instrumentation must provide enough dynamic range at both FR1 and FR2 to characterize and validate consistent performance for components across the 5G frequency ranges.

## RF-to-RF Beamformers

When testing 5G beamforming devices such as the one in Figure 13, engineers need to sweep over large frequency bands to test the maximum linear output and compression behavior of each path. They also must check the attenuator step error and phase offset deviation per step. For the receive path, they need to characterize the noise figure versus frequency, as well.

Considering that the signals are bidirectional, the simplest method to test would be to reverse the connections to the test instruments, but for efficient characterization and validation test, this is simply not realistic for multiport devices with 8, 16, or more ports with horizontal and vertical polarizations. The test instrumentation must include a fast, bidirectional switching solution designed for multiport testing.

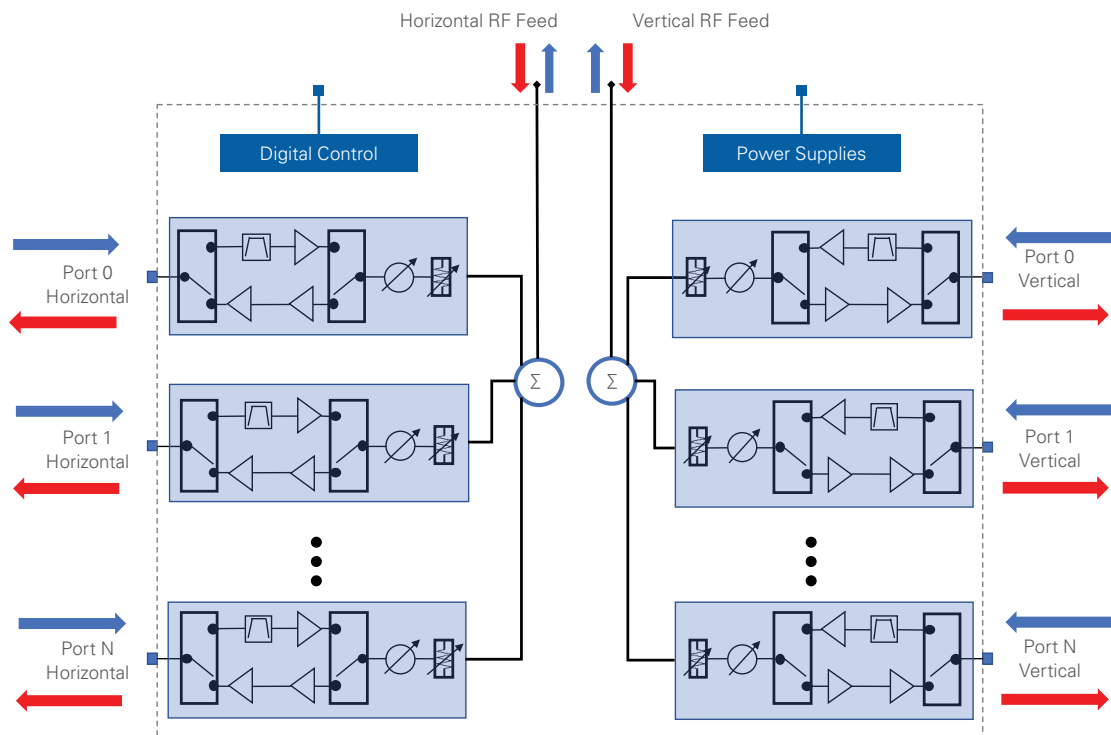

Figure 13. Beamformer IC With Horizontal and Vertical Polarization

### IF-to-RF Beamformers

Other types of beamforming devices (IF-to-RF beamformers) take in intermediate frequencies (IF) and upconvert them to RF. Conversely, they take in the received RF signals and downconvert them to IF (see Figure 14). As discussed above for RF-to-RF beamformers, engineers also need to characterize the performance of these components over frequency, measuring the amplitude and phase changes per step, and checking for proper frequency translation while minimizing frequency images and high-order effects. IF-to-RF beamformers present an additional measurement challenge because they require IF generation and analysis at different intermediate frequencies, depending on the frequency plan for the specific device design. For example, some DUTs operate with an IF at 8 or 12 GHz, while others set their IFs at 18 GHz.

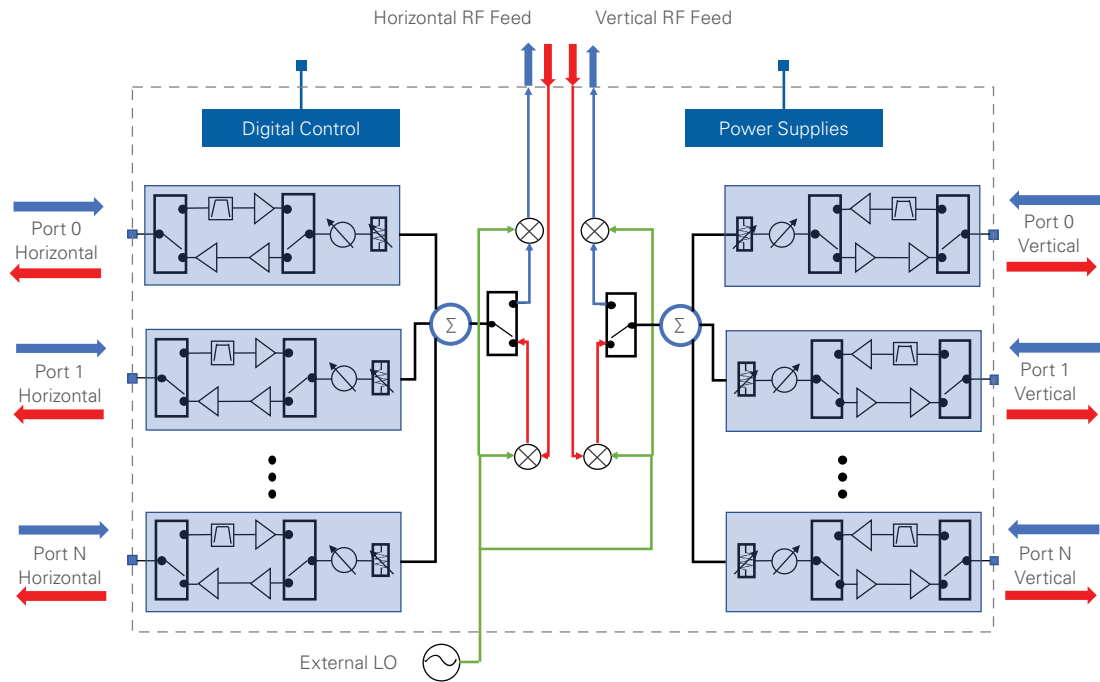

Figure 14. IF-to-RF Beamformer Device

Engineers need to characterize and calibrate the following sources of error in these 5G beamforming devices to ensure proper transmitted power, accurate steering, and reliable sensitivity:

- I/Q impairments and signal flatness: This requires understanding and locating the source of I/Q impairments for equalized output over large bandwidths.
- LO phase noise and frequency drift between modules: Antenna arrays that rely on aggregation of multiple beamformer circuits can suffer from differential phase noise between them because they share a common reference but not a common LO. This error can also take place when the signal paths for LO distribution are so proportionally large that they decorrelate the phase error between them. Similarly, uncorrelated ADC/DAC baseband sampling clocks lead to frequency drift between modules.
- Phase differences between antenna elements: It's important to determine how phase errors are affecting the direction (angle) of the beam and/or the null locations and power. As mentioned in the previous section, device characterization needs to take into account thermal effects that the PAs are introducing, loose tolerances in the RF feeding network, and group delay variations in the filters.
- Signal tapering control: Controlling the amplitude of the signal at each element affects the sidelobe levels and the main lobe peak gain. As the devices' PAs and LNAs go into compression and heat up, especially when the component density in the package is very high, thermal droop can cause large amplitude errors.
- Isolation and mutual coupling: This involves checking that the effects of the signal from one path to another are minimal, because mutual coupling between antenna elements and signal paths impairs MIMO operation and signal demodulation.

## Digital Control Challenge

Automating multiband FEM and multichannel beamformer characterization also requires very fast and streamlined digital DUT control. Many times, engineers need to implement overclocked versions of digital protocols, such as serial peripheral interface (SPI) and MIPI, to exercise their DUTs under real-life application use cases. For example, with beamformers, it's critical for the device to keep up with the beam agility requirements of 5G (beam searching, matching, tracking, and beamforming, among others). This requires very fast state changes. To cope with this demand, test benches require digital instruments capable of implementing digital protocols at higher speeds.

## NI Solution

The NI test solution, based on PXI instrumentation and flexible test software, empowers engineers to configure fast, time-synchronized, phase-coherent multichannel test systems for automated RFIC characterization, validation, and production test.

Using the latest multicore processors produces faster, parallelized measurements to address growing test cases. Also, it incorporates a wide range of fast digital predistortion algorithms, and it gives users the ability to deploy their own custom algorithms for real-time execution and visualization of PA performance.

The tight instrument synchronization necessary for measuring and testing envelope-tracking PA/FEMs is built into the PXI platform. Addressing the needs of higher bandwidth power modulators for 5G waveforms is simplified with the large instantaneous bandwidth of the baseband VST. Furthermore, the large collection and wide availability of PXI instruments (VSTs, source measure units, digital cards, and scopes) helps engineers configure complete PXI test benches in one chassis.



Figure 15. Integrated PXI Bench for FEM Test With DPD and Envelope Tracking.

Additionally, the NI PXI platform gives engineers high-speed digital I/O instruments specifically made for semiconductor engineers looking to control and test ICs. The digital instruments work on the concepts of drive formats and time sets, and include a rich software experience with NI's Digital Pattern Editor to provide extensive debug and characterization tools, such as digital scope. These tools help engineers burst patterns to write to and read from new beamforming ICs at speeds greater than what today's popular SPI or MIPI protocols allow.



These powerful tools assist with debugging during test development and facilitate quick understanding of device performance across multiple parameters.



Figure 16. NI Digital Instrument for Fast Digital Control and Test

The mmWave VST includes several connectivity options to interface with different DUT types. For testing RF-to-RF beamformers, it uses the dual-port, bidirectional mmWave head to generate 5G wideband stimulus signals to the beamformer's horizontal and vertical inputs. The VST's other mmWave head, in an enclosure fanning out to 16 switched ports, can route the DUT's output to the VST for fast waveform analysis. The signal direction can easily be reversed to test the beamformer receiver, thanks to the duplex nature of the mmWave VST, as Figure 17 depicts.

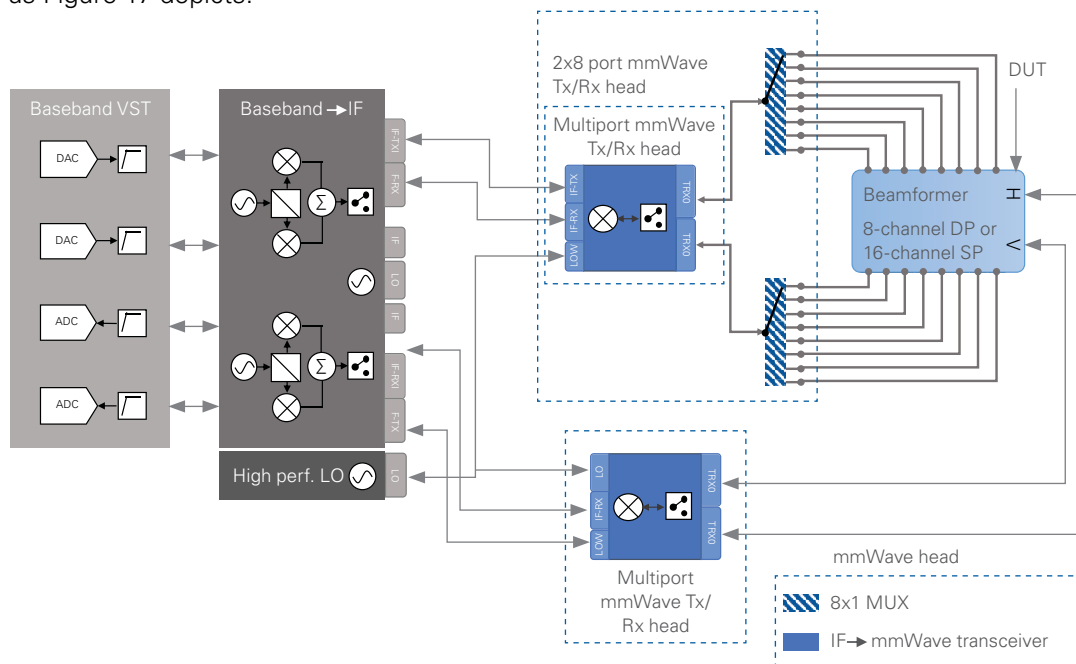

Figure 17. Using the mmWave VST to Test RF-to-RF Beamformers

Similarly, testing IF-to-RF beamformers becomes simpler using the calibrated IF ports out of the mmWave VST. The instrument can generate the stimulus IF signal into the horizontal and vertical IF ports of the DUT, and measure the upconverted signal on all beamformed ports using the VST's switched mmWave head. Conversely, the mmWave VST can generate 5G mmWave signals into each of the beamformer's ports and acquire the resulting IF signals for fast analysis using the calibrated IF ports on the VST, as Figure 18 shows.

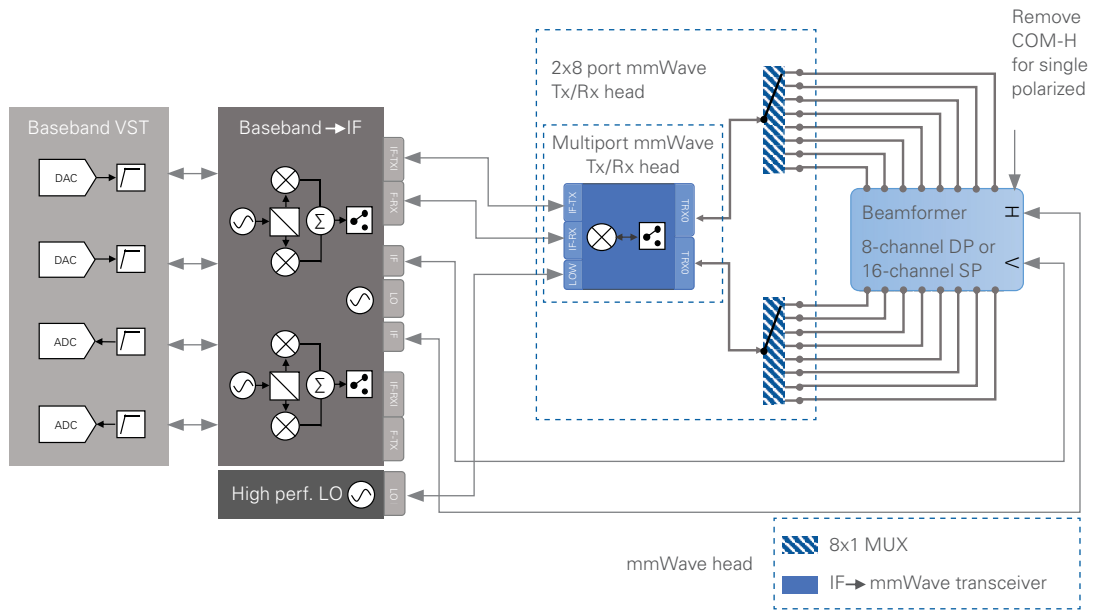

Figure 18. Using the PXIe-5831 mmWave VST to Test IF-to-RF Beamformers

Having multiple bidirectional mmWave ports also enables simpler test setups for assessing the performance of multichannel FEMs, as illustrated by Figure 19 below.

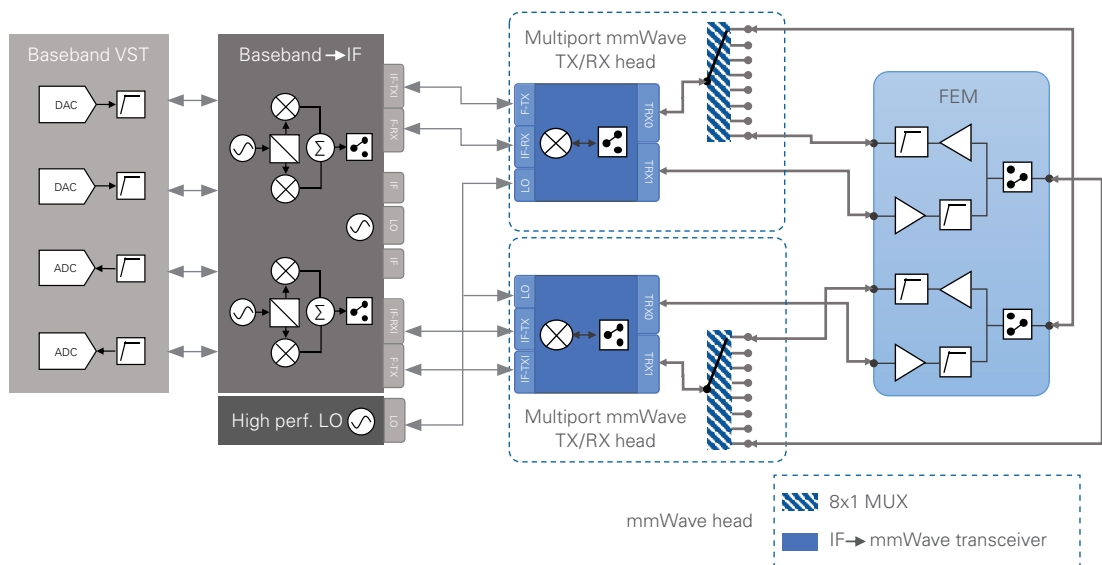

Figure 19. Dual-Channel TX/RX Front-End Module

## IV. Testing Massive MIMO and Beamforming Over the Air

In a Massive MIMO system, the number of base-station antennas far exceeds the number of user terminals. Using this concept, the 5G standard specifies Multiuser MIMO (MU-MIMO) technology, in which the base station feeds the active antenna systems with precoded signals that multiplex in space several simultaneous streams to multiple users, such that each receiver can pick up its own independent data stream. To achieve this spatial multiplexing, the gNB needs to target the individual receivers by beamforming the radiated energy to each one. With beamforming, engineers can implement MU-MIMO to boost gNB capacity and can decrease transmitted energy use. At mmWave frequencies, it's imperative to boost the link budget by dynamically beamforming the radiated beam in the direction of the UE. Another benefit of beamforming is that it can create and steer signal nulls to reduce cochannel interference, ensuring high throughput.

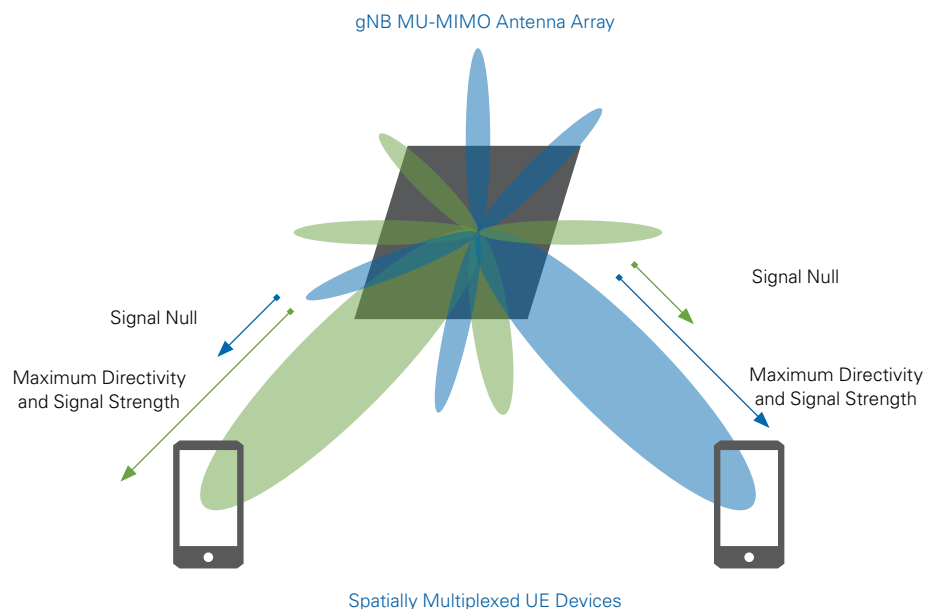

Figure 20. Spatial Multiplexing Using Beamforming

As the 5G industry moves into wide commercialization, both infrastructure and UE components become more integrated and miniaturized. Although some components continue to have accessible coaxial connectors for characterization and validation of every RF path in the lab, many beamforming systems will likely do away with their antenna connectors due to the added complexity and cost of managing and testing tens or hundreds of connections, physical size limitations, and higher insertion loss. The current trend is toward integrated antenna-on-chip (AoC) and antenna-in-package (AiP) devices for beamforming at mmWave frequencies that have no available RF test ports, forcing the industry to look for test systems that can characterize their devices using radiated, over-the-air (OTA) measurements.

Figure 21 shows a block diagram of the various subsystems that make up a 5G radio using hybrid beamforming devices. UE devices likely can integrate several subsystems into a single AiP chip that oversees the beam steering, front-end functionality, and antenna array. Infrastructure devices going into gNBs that need to radiate orders of magnitude more power than UE likely can implement this functionality through more discrete subcomponents,

especially the front-end pieces that rely on different semiconductor technologies such as higher power gallium arsenide or gallium nitride devices.

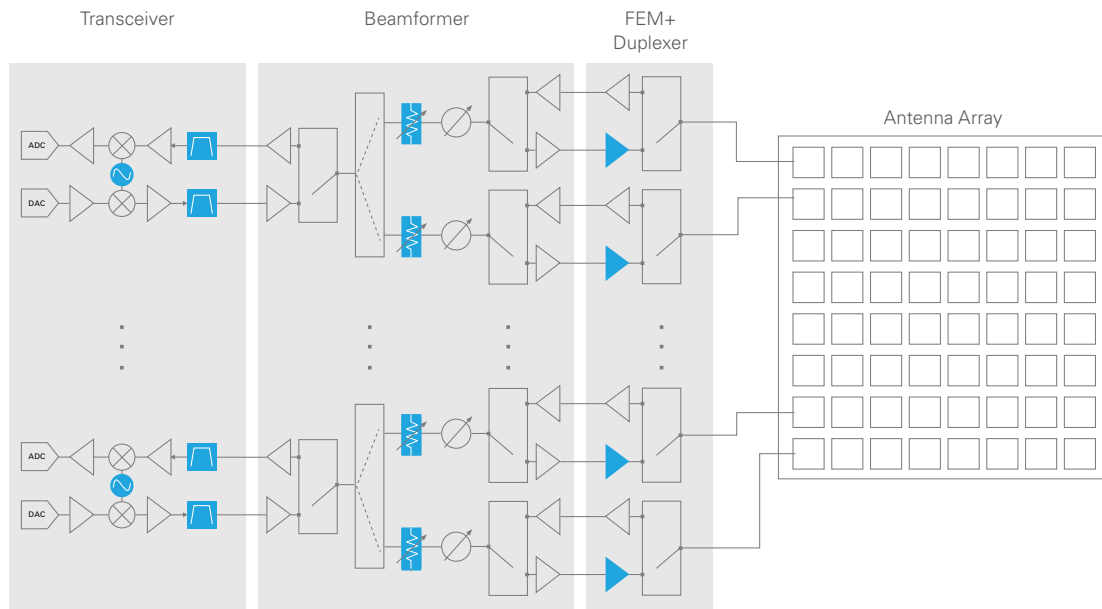

Figure 21. Block Diagram of 5G Radio With a Transceiver, Beamformer, and FEM

### OTA for More Accurate Characterization

In many cases, the antenna array impedance is not close to the ideal  $50\ \Omega$ . When testing with  $50\ \Omega$  instruments, the PA output behaves differently than when it's connected to the antenna array. This introduces errors in effective isotropic radiated power (EIRP) and total radiated power (TRP) performance. Antenna loading conditions also decrease PA efficiency and introduce harmonics, intermodulation, and other undesired effects. On the receiver side, as the received signal goes through bandpass filters, the evaluation of the receiver paths doesn't become overly sensitive to the antenna impedance. However, 5G AoC and AiP devices have antennas that are tightly coupled to the radio, such that the radio noise might change the antenna temperature, affecting the effective isotropic sensitivity (EIS) and total isotropic sensitivity (TIS)<sup>1</sup>. OTA measurements more accurately measure the actual RF performance of chipsets when there's noise coupled from the antennas to the radio.

### Far-Field Measurement Challenges

As engineers transition from traditional conducted RF semiconductor tests to OTA test methodologies, they have the challenge of setting up dynamic OTA test systems that give them realistic RF performance. Consequently, engineers perform OTA characterization and validation tests by placing the DUTs at specific distances and angles from the measurement system in very controlled RF environments within anechoic chambers.

As depicted in Figure 22, an antenna with a certain aperture "D" (that is, its effective area, or receiving cross-section; a measure of how effectively an antenna can receive a signal) produces an electromagnetic field that can be located in three specific regions: the reactive near field, the radiating near field, and the radiating far field.



Figure 22. Antenna Measurement Regions

Although many researchers are investigating near-field testing to avoid sizable RF chamber setups, positioning the sampling antenna too close to the DUT introduces several concerns. Some of the hardest for accurate characterization are<sup>2</sup>:

- Avoiding the coupling of energy from the DUT into the measurement system in the radiated near field
- Having to sample accurately not only amplitude but phase for proper conversion of near-field to far-field measurements
- Evaluating EVM, ACLR, or SEM, because near-field to far-field conversion works best for measuring carrier propagation, but the results are not as reliable with high-bandwidth modulated signals<sup>3</sup>

For mmWave devices with wavelengths of only a few millimeters, a properly designed RF chamber doesn't have to be as large as existing setups for testing sub-6 GHz devices. 5G mmWave OTA RF enclosures can be 1 m or smaller for meeting far-field testing conditions<sup>4</sup>, as shown in Figure 22. The main challenge here is not the size of the chamber but:

- The location of the sampling antenna(s)
- The mechanical design of the DUT positioner with at least two axes of freedom that can maintain a polarization reference
- The enclosure's shielding effectiveness
- The ability to conduct thermal cycling tests without environmental damage to the chamber
- Proper characterization of the quiet zone—a rectangular volume where electromagnetic waves reflected off the walls, floor, and ceiling remain below a specified minimum

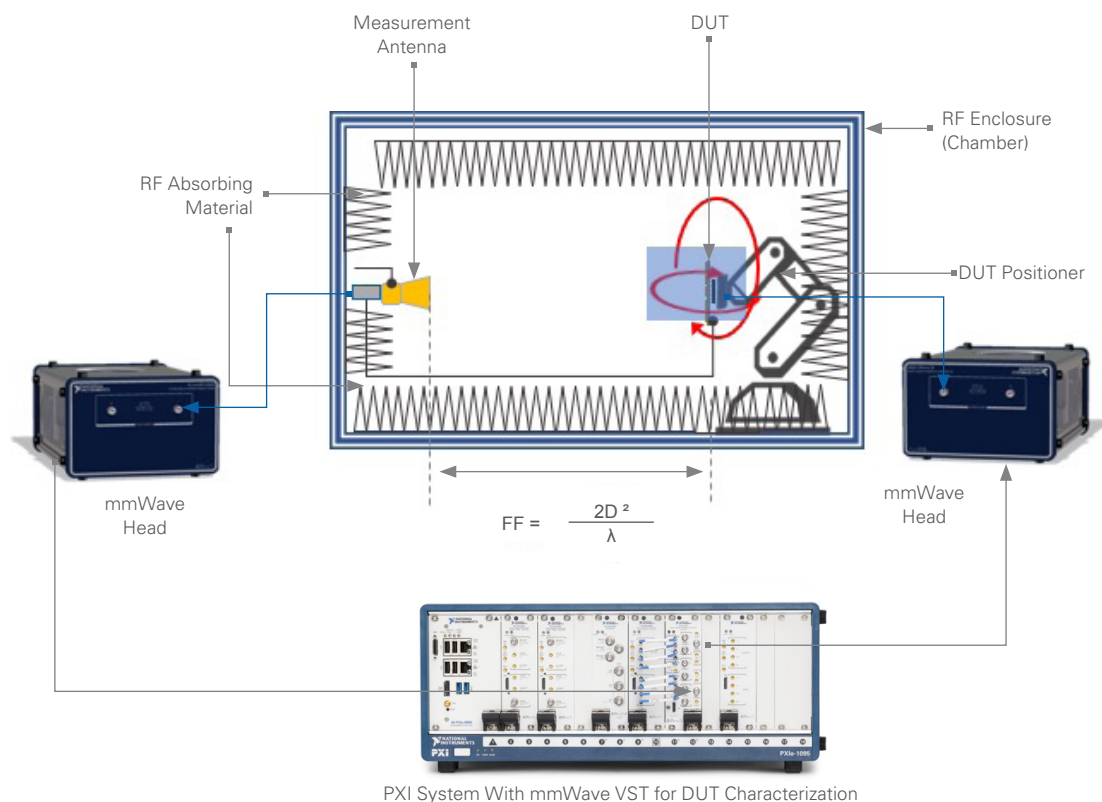

Figure 23. Test Setup for 5G OTA Tests

## Thermal Test Challenges

Highly integrated mmWave phased arrays have a tough challenge in terms of antenna element spacing and thermal management. Considering that the size of the array scales with the wavelength, it becomes increasingly complex to fit all of the electronics within the array at mmWave frequencies. That is, for a set number of elements, an array designed for operation at 20 GHz will be twice as large as an array designed for 40 GHz.

Additionally, the radiated power might be the same for both designs, but the density of DC power that the higher frequency device needs to dissipate has quadrupled. This forces engineers to design, and thoroughly characterize and test, devices for proper thermal management and derating. It also places restrictions on the power level that each transmit path and antenna element can handle. Fortunately, the EIRP scales with the square of the number of elements, allowing for high-power systems with a modest increase in the number of array elements.

In terms of the receiver paths, the challenge resides in designing low-noise systems and characterizing the performance of the antenna gain to receiver noise temperature, or G/T. Unlike the EIRP, which increases with the square of the number of elements, G/T only scales linearly with the number of elements. This increases the burden on the receive chain design and test. Additionally, the loss between the antenna and the LNAs represents a critical factor that degrades the receiver sensitivity directly.

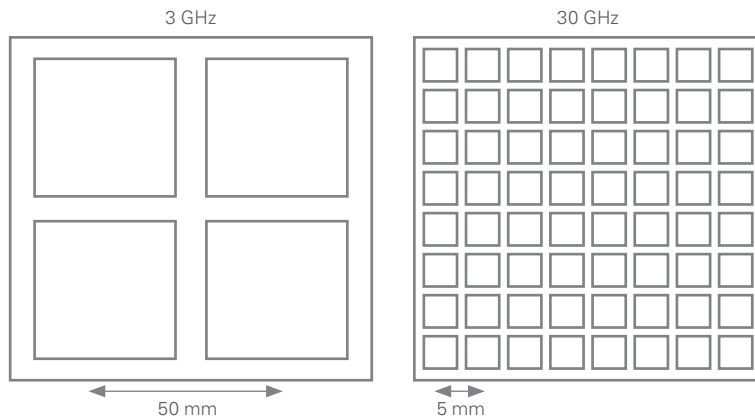

PA POWER VERSUS NUMBER OF ANTENNA ELEMENTS

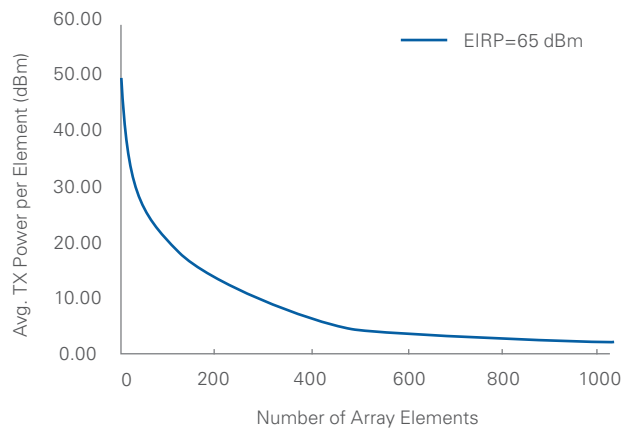

Figure 24. Average Tx Power per antenna array element

Engineers performing thermal device characterization need a way to run OTA test sequences while submitting the DUT to wide thermal cycles. However, the materials inside the chamber, such as the RF absorbing foam and mechanical positioner parts, can be damaged with frequent temperature and humidity swings. Part of the OTA characterization challenge is to perform efficient thermal testing that minimizes thermal mass and avoids damaging the chamber or interfering with the RF measurements.

**Spatial Scanning Test Challenges**

The 3GPP standard specifies OTA testing procedures that help engineers determine new beamforming performance in terms of beam center, beam width, EIRP, TRP, and sensitivity.

Figure 25 illustrates the procedures that engineers need to follow to test their devices OTA.

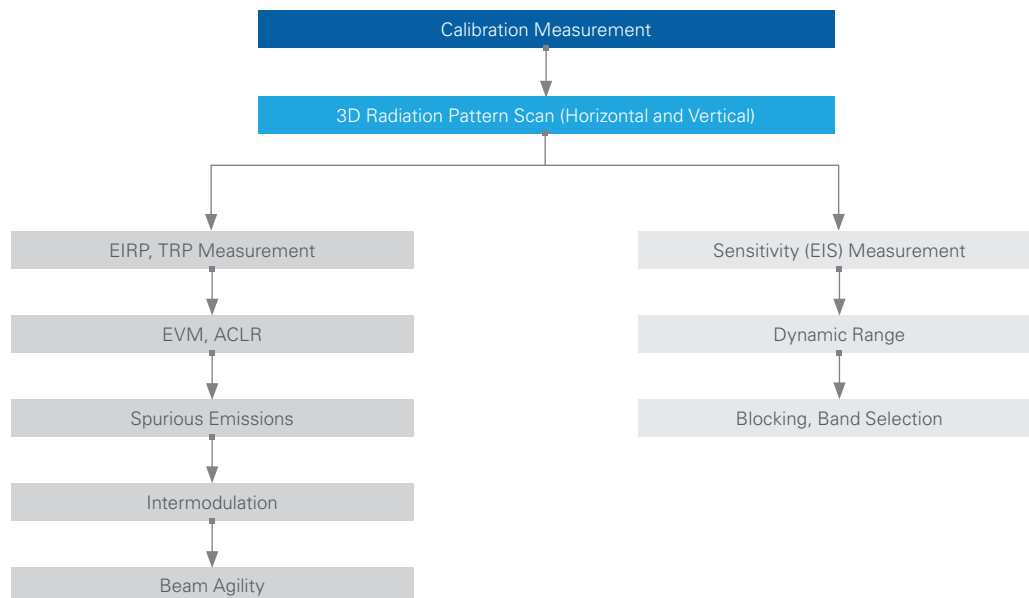

Figure 25. OTA TX and RX Test Procedures

## OTA Calibration Procedure

The first step is to calibrate the measurements using a feed antenna and a reference antenna with known gain values. This reference antenna goes to the center of the quiet zone on the DUT positioner, while the measurement antenna remains on the measurement plane in the far field. The calibration process measures the composite loss of the entire transmit and receive paths. This includes any antenna and amplifier gains, as well as losses through the air interface, cables, switches, and combiners. Engineers repeat the calibration measurement for each measurement path and each polarization.

## 3D Radiation Pattern

After calibrating the system, engineers feed a modulated 5G test signal to the DUT and perform a spatial scan separately for each orthogonal polarization using a grid like the ones shown in Figure 26. That is, at each spatial point, the mmWave signal analyzer captures a TX power reading for each polarization and the test system stores the results. Afterward, the measurement system returns the DUT's 3D radiation pattern and the TX beam peak direction. Engineers then drive their DUT so that its generation remains locked in that specific direction for the duration of the subsequent tests.

## Radiated Power and Modulated Tests

Not only must engineers characterize their device by measuring the EIRP in a specific direction, but their test solution also must integrate the power measured at each point on the grid, for each polarization, to compute the TRP. Adding to the technical challenge of producing these results is the fact that traditional measurements such as EVM, ACLR, and spectral emissions are also spatially dependent. Reflected signals in the test area (in the quiet zone) must be attenuated enough to maintain the measurement uncertainty (MU) below predefined values. For example, the 3GPP study on test methods<sup>5</sup> states that, to measure EVM, engineers must:



1. Find the TX beam peak direction with a 3D EIRP scan using the predefined grid
2. Lock the beam in that direction for the duration of the test
3. Measure EVM for phi and theta polarizations of the modulated signal

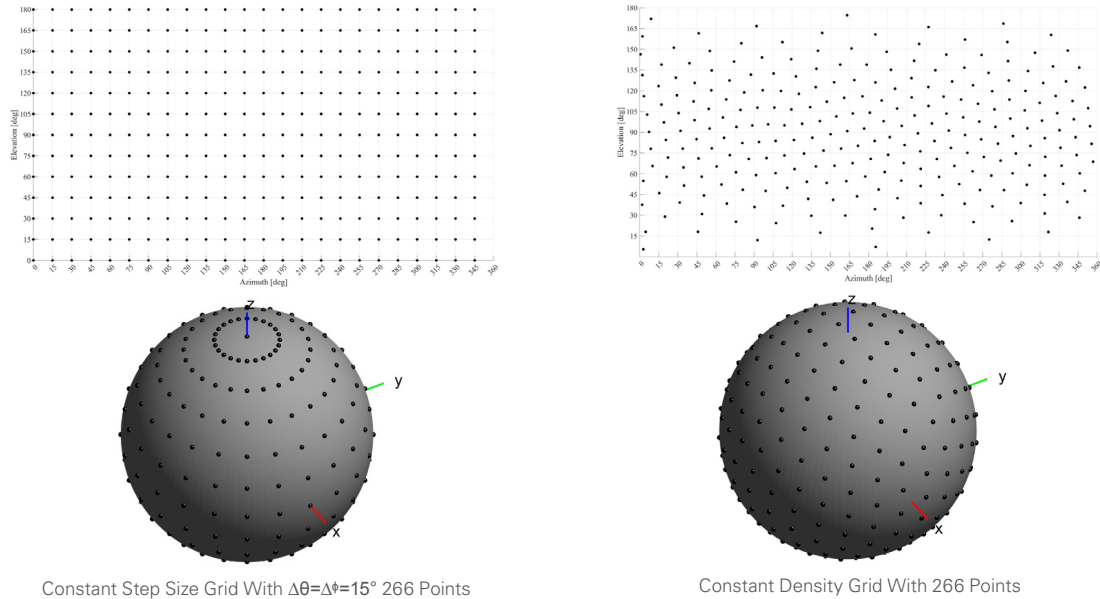

Figure 26. OTA Spatial Scan Grids

## Receiver Tests

Engineers also must test the sensitivity of their 5G devices and determine EIS. When testing a complete 5G radio, the measurement system establishes a connection with the DUT by applying a downlink signal. The test system must determine the power level for each polarization ( $\theta$  and  $\phi$  at which the throughput exceeds the requirements for the specified reference measurement channel). The system then returns the RX beam peak direction where it found the minimum EIS.

Using that same RX beam peak direction, the receiver also must be characterized for dynamic range and its ability to reject in-channel blocking signals with  $\theta$  and  $\phi$  polarizations. This introduces the challenge of simultaneous 5G signal generation for connecting with the DUT and the wideband interferer.

## Fine Spatial Grids and Test Time Challenges

As engineers conduct their OTA characterization and validation tests using the grids specified by the 3GPP, they may realize that their measurement accuracy needs improvement. The beam peak direction might not exactly align with the sampling point in space, introducing measurement error. This error is more pronounced near the pattern zeros, as the pattern changes very rapidly by angular unit.

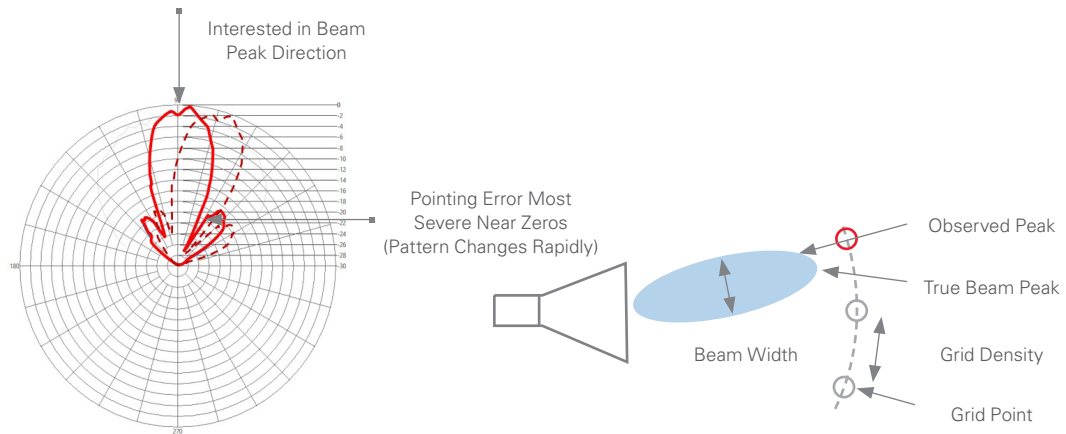

Figure 27. Beam Peak Measurement Error Due to Coarse Sampling Grid

Statistically, the finer the sampling grid, the smaller the measurement uncertainty. However, the challenge is that the test time increases with finer grids. Consider the following test scenario:

$$\text{Total test time} = (\text{positioner displacement time} + \text{measurement time}) * \text{grid size} * 2 \text{ (polarizations)}$$

Typical positioner displacement time + measurement time per point: 0.25 seconds

Tests: TxP, EVM using 100 MHz 5G New Radio waveform

No. of Grid Points (Constant Density)	Test Time	Mean Error (dB)
6,000	3000 s (50 min)	0.02
2,000	1000 s (16.7 min)	0.07
800	400 s (6.7 min)	0.2
600	300 s (5 min)	0.24
200	100 s	0.74

Table 3. Typical Test Time and Measurement Error for Various Sampling Grid Sizes

The results of Table 3 apply to measurements at a single frequency. Consequently, there’s a test time challenge when characterizing the performance of a device over large bandwidths. For example, if the system performs the spatial scan over 4 GHz of bandwidth every 100 MHz using a 2,000-point grid, those 40 spatial sweeps would take more than 11 hours to complete.

Researchers have run lengthy simulations on the effect of the beam peak offset and observed that practical measurement grids with fewer than 1,000 unique measurement points can yield errors (max EIRP - beam peak EIRP at grid point) of less than 0.2 dB and standard deviations of less than 0.2 dB<sup>6</sup>.

Also, after getting thousands of simulation results measuring the max EIRP versus the beam peak EIRP for various density grids, researchers have concluded that an MU systematic error term should be based on the determination of the offset from the beam peak that contains 95% of the measurement samples or the value that represents a cumulative density function of 5%. The simulation results showed that these grids with fewer than

1,000 points on the grid can yield offsets from beam peak at which cumulative distribution function is 5% of less than about 0.5 dB<sup>7</sup>.

The current guidance, based on simulation results for making a reasonable trade-off between test times and measurement uncertainties, is to use the following measurement grids for beam peak search, leading to a systematic error of "beam peak search" of 0.5 dB:

- Constant density grid with at least 800 grid points
- Constant step size grid with at least 1,106 grid points, corresponding to an angular step size of 7.5°

However, this test procedure can improve by using an initial coarse search followed by a fine search, significantly reducing the number of beam peak search grid points. That is, use a coarse grid to identify candidate regions where the beam peak might be, and then refine the search using a much finer grid in the second stage, as illustrated in Figure 28. Engineers can apply this approach for RX beam peak search, as well.

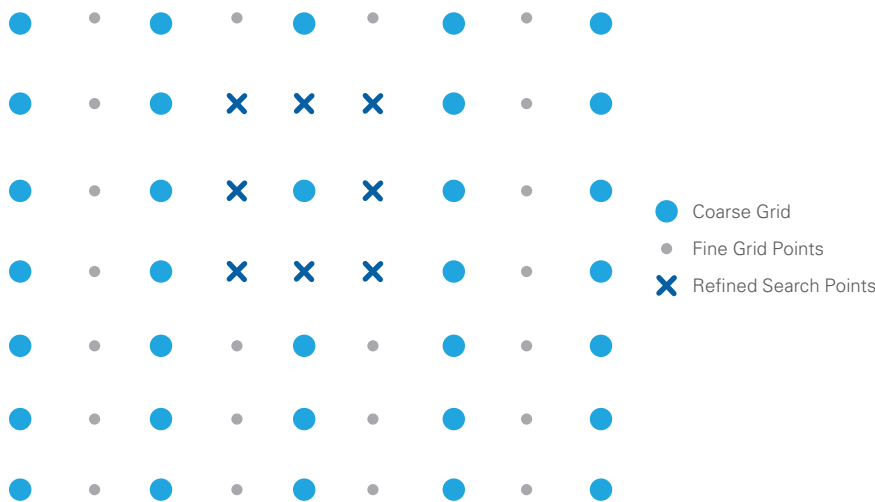

Figure 28. Optimized Beam Peak Search With Coarse Grid

## mmWave Measurement-Uncertainty Challenges

There are several contributors to OTA MU. Engineers relying on OTA test solutions must aggregate these factors to calculate an error budget for all of their measurement results. Dividing these sources of uncertainty into three main categories can help engineers understand them and mitigate their effects:

1. **Systematic errors:** These usually come from test setup and test instruments and may occur because they aren't properly calibrated or present a consistent offset. Also, the users might be manipulating the instruments incorrectly.
2. **Calibration measurements:** There are several challenges associated with the various parts of the OTA system, such as controlling the quality of the quiet zone; locating the reference and measurement antennas for proper alignment and distance (far field); eliminating standing waves and mutual coupling; and accurately determining their absolute gain.

3. **DUT measurements:** Using the right measurement grid density for diverse DUTs, as outlined above, leads to more reliable results. So does having sturdy mechanisms for ensuring that the DUTs always get placed on the positioner at the same distance and angle from the measurement antenna; and controlling any signal leakage through all connectorized interfaces.

Further investigation into addressing OTA measurement uncertainties leads to separating the sources of uncertainty into the system subcomponents:

1. Measurement equipment
2. Chamber
3. Positioning
4. Measurement and reference antennas

### Measurement Equipment Challenges

When calibrating the total path losses of OTA test setups for mmWave devices, engineers must accurately determine the broadband RF power. Initial efforts to calibrate for power measurements at mmWave frequencies involved the use of several diode sensors to cover the frequency range, but technology is moving toward broadband power sensors based on thermocouple technology. They can calibrate the broadband power for the whole 5G mmWave bands, from 24 GHz to 52 GHz. Also, using a single connection decreases potential errors from a multisensor setup.

When switching to continuous wave and modulated waveform measurements with vector signal generators and analyzers, engineers must account for compounded uncertainties along the signal paths due to the instrumentation's insertion losses, output and input impedance match, and flatness and amplitude accuracy specifications. They also must keep in mind the effect of noise as a systematic error in low signal-to-noise ratio test scenarios.

### RF Chamber Measurement Challenges

Power and phase variations over frequency and space result from direct and reflected waves adding vectorially at the measurement antenna. Therefore, the anechoic chamber needs to simulate a free-space propagation without reflection as much as possible. However, it's very difficult to obtain a direct wave without reflections. That's why engineers must strive to create a quiet zone in which the DUT gets placed and encompassed completely. In this area, power and phase variations due to reflectivity are minimized. Although variations tend to average out for spatially integrated values such as TRP, the quality of the quiet zone can have a large effect on more pointed EIRP measurements.

Engineers trying to create a quiet zone and measure its performance face a grand challenge that requires measuring with a reference antenna placed at various individual reference points and orientations. They typically need to correct for differences in measurement distance and antenna directivity due to off-boresight pointing. This detailed task can consume hours and require careful attention to measurement results.

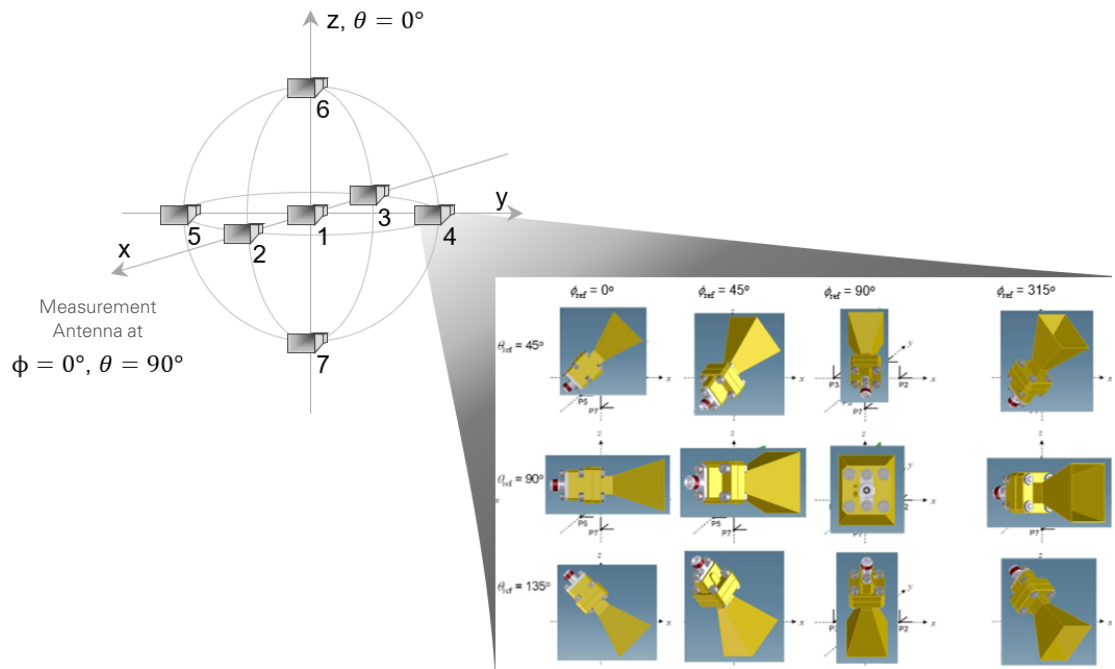

Figure 29. Characterizing the NR mmWave Quiet Zone

Other sources of uncertainty and measurement errors inside the chamber include phase curvature due to different aperture sizes between the measurement and the DUT antenna aperture, and standing waves between antennas with high-directivity or due to short distances.

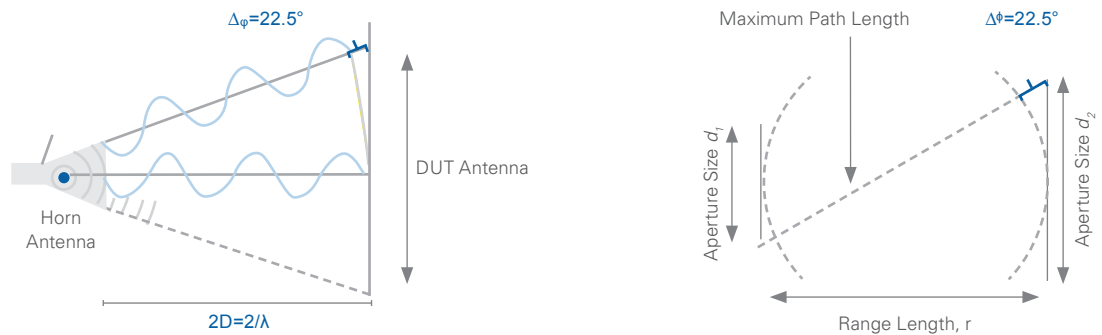

Figure 30. Phase Curvature Across Antenna Aperture

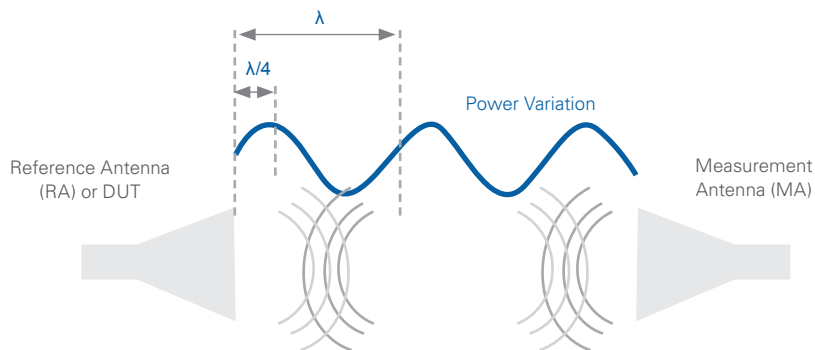

Figure 31. Standing Waves Across Antennas

The amount of noise that cables and connectors can pick up is not necessarily negligible. It can add several dB of uncertainty<sup>8</sup>. Many designers tackle this challenge by rerouting the cables inside the chamber, specifying higher cable shielding, and covering the cables with RF-absorbing materials.

### Positioning Measurement Challenges

As the DUT's antenna orientation deviates from its calibrated azimuth and elevation position, the antenna pattern that the measurement antenna sees changes. Many times, there's an angular deviation due to positioner mechanical play or uncertainty, and loose fixturing that prevents consistent and repeatable DUT mounting. The effect on the power measurements depends on the type of measurement. Integrated measurements such as TRP suffer less than beam peak measurements such as EIRP.

Careful DUT positioner design also can avoid error introduced by rotational axes in the form of phase center offsets. That is, the measurement distance between antennas would change with the angle rather than staying on a preconfigured measurement plane.

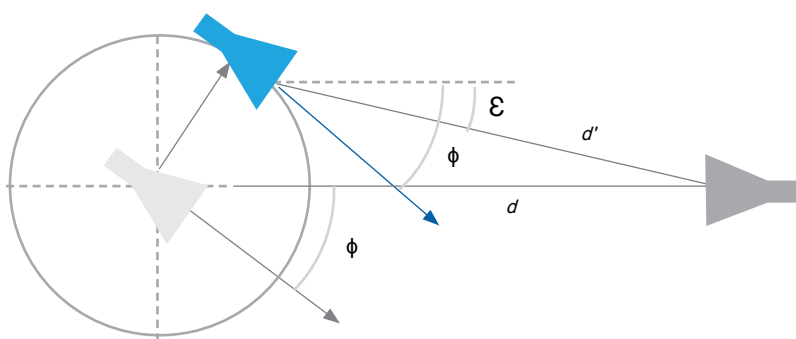

Figure 32. DUT phase center offset from rotational axes

It's also important to verify the alignment of the reference and measurement antennas to avoid reducing the reference antenna's gain toward the measurement antenna, especially because system calibration relies on using the maximum antenna gains for computing path losses.

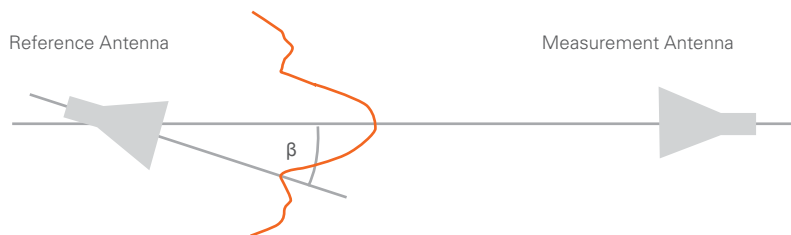

Figure 33. Antenna-Pointing Misalignment

After calibration with a reference antenna, engineers mount the DUT on the positioner. However, they must consider the measurement uncertainty derived from the misalignment of the two measurement planes, as Figure 34 depicts.

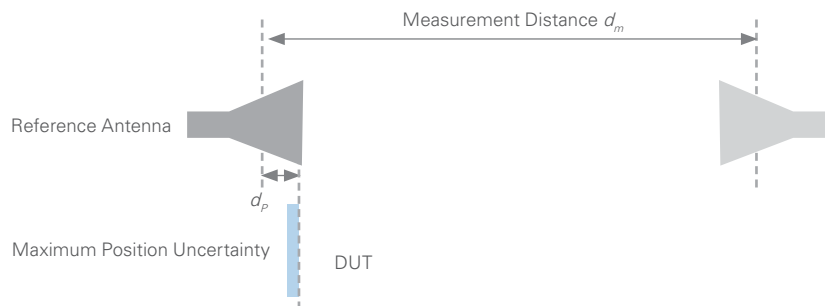

Figure 34. Misalignment Between Reference Antenna and DUT

### Antenna Measurement Challenges

Antennas inside the chamber have finite isolation against incident field components cross-polarized to their own polarization. That is, a vertically polarized antenna picks up some power from the horizontally polarized signal, and vice versa. This affects the measurement results depending on the amount of cross-polarization isolation. In the worst-case scenario, an antenna demonstrates high cross-polarization leakage and sees vertically and horizontally incident waveforms, with the leakage component perfectly in phase.

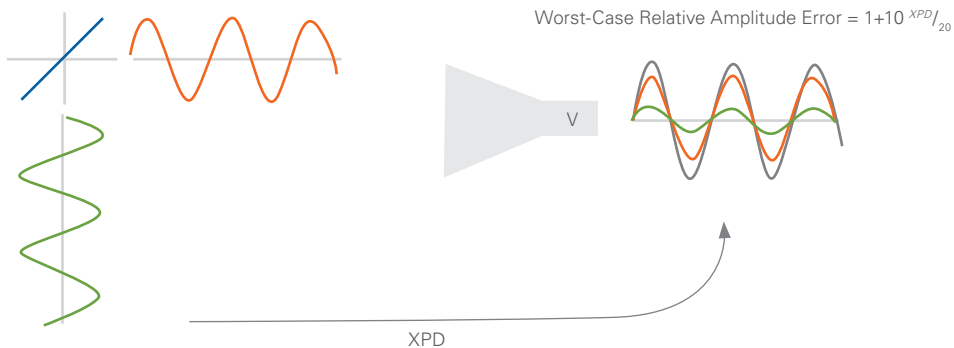

Figure 35. Cross-Polarization Discrimination

Engineers must deal with another source of error from the reference antenna feed cable, which is present only in the calibration stage and may disappear or change when testing the DUT. Routing, bending, and rotary joints also affect measurements.

### Procedural Measurement Challenges

Finally, to summarize this section on OTA measurement challenges, there also are some procedural sources of uncertainty. As mentioned, variation in insertion loss between the calibration stage and DUT measurement stage introduces uncertainties. That is, the calibration antenna might present a better 50 Ω match and require different cabling than the DUT. As a result, the calibration values won’t be affected as much by the insertion loss as when engineers introduce a DUT that requires different cabling and presents a different impedance to the measurement system.

Also, engineers working with certain DUTs might not know where exactly within a device the antenna array is. The so-called “black box” test<sup>9</sup> can introduce uncertainty because the measurement distance differs from the expected antenna position on the test fixture.

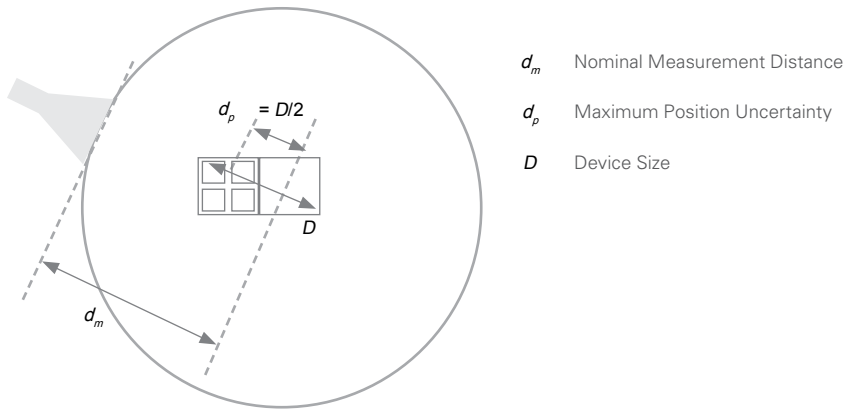

Figure 36. “Black Box” Measurement Distance Uncertainty

Sampling a spatial grid and computing the power density over a spherical surface at a fixed distance from the DUT also introduce measurement uncertainties. As mentioned, the antenna beam width and sidelobe suppression, together with the sampling grid arrangement and density, play a critical role here. Consider that the TRP is an integral of the individually sampled EIRP. In the case of the constant step size grid:

$$TRP = \int_{\Omega} \frac{EIRP(\theta, \phi)}{4\pi} \cdot \sin \theta \cdot d\theta \cdot d\phi$$

But the measurement system approximates the result by sampling and numerically summing the power density values. The 3GPP documents some methods for combining the samples, with an estimated measurement uncertainty for each one. Table 4 illustrates expected measurement uncertainty for a reference 8x2 antenna array with λ/2 spacing.



Number of		Mean Error (dB)	STD (dB)	Min. Norm. TRP (dB)	Max. Norm. TRP (dB)	Integration Approach	Comment
Latitudes	Longitudes						
12	19	-0.03	0.25	-1.17	0.77	sin( $\theta$ ) Weights	$\Delta\theta=16.36^\circ$ and $\Delta\theta=18.95^\circ$
		-0.01	0.20	-0.92	0.76	Clenshaw-Curtis Weights	
		0.00	0.26	-1.01	0.84	Jacobian Integration	
		0.00	0.21	-1.00	0.73	Jacobian Ferromagnetic Integ.	

Table 4. Statistics of Quadrature Approaches for Constant Step Size Measurement Grids for 8x2 Reference Antenna Array

The following chart offers a modeled assessment of expected measurement uncertainties accounting for the uncertainty contributions of the various sources of measurement error previously described.

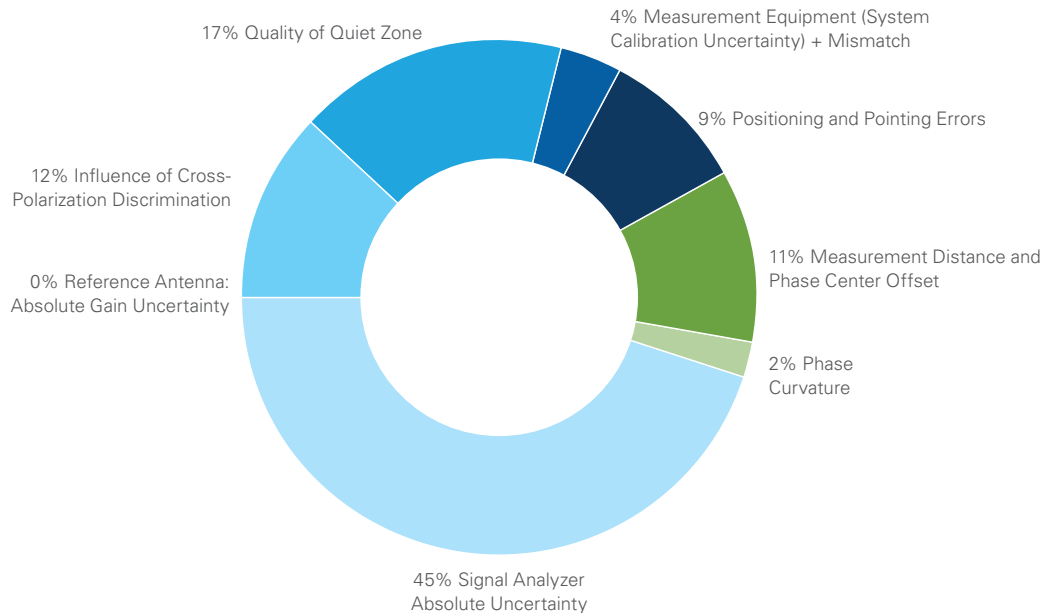

Figure 37. 3GPP EIRP Measurement Uncertainty Contributions

**NI Solution**

For mmWave semiconductor engineers who need RF-to-RF or IF-to-RF OTA performance characterization or design validation of AiP devices or antenna modules, the NI mmWave OTA reference design gives them the ability to measure accurately the complete radiated field of their DUTs in all transmitting directions.

**Faster Test Speeds Through Hardware-Timed Motion Control**

Unlike software-based measurement systems that instruct the DUT positioner to accelerate, stop, and measure at each point on the spatial sampling grid, NI takes advantage of sub-nanosecond timing and triggering capabilities to cut test times dramatically. The NI OTA reference solution implements a hardware-based, real-time motion control system to drive the DUT positioner many times faster, swiftly sweeping the spatial grid while triggering rapid 5G RF measurements. This results in much shorter test times, increased repeatability,

and reduced nondeterministic relationships between the measurement instruments and the motion components.

The NI mmWave OTA reference solution integrates real-time motion control with the wideband capabilities of the mmWave VST, a high-isolation anechoic chamber, a DUT positioner, and, if needed, RF-transparent thermal enclosures for the characterization of DUTs over temperature. The system diagram below (Figure 38) depicts the NI mmWave OTA reference solution and shows the components that give engineers an advanced powerful test setup to characterize and validate their mmWave beamforming DUTs.

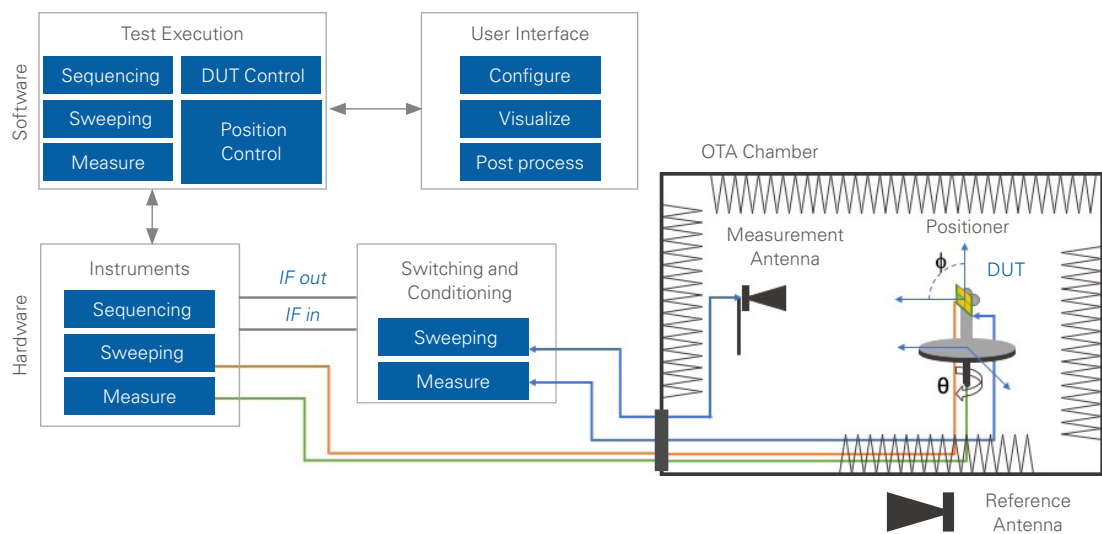

Figure 38. NI mmWave OTA Reference Solution Diagram

After fast execution, the test sequencer gives engineers results for measurements such as EIRP, TRP, EVM, and half-power bandwidth, among others. Additionally, engineers can take advantage of various visualization tools, such as 1D cut analysis, 1D polar plot, 3D antenna pattern, heat map, and best beam index.

The graphical user interface of the mmWave OTA reference solution provides a way to configure the execution with many different measurement parameters, sweeping parameters, and connection settings. It also executes the postprocessing algorithms and presents the measurement results in easily digestible reports. The test execution engine receives the configuration parameters from the user interface and runs the test sequence, controlling the DUT, positioner, and instrumentation for accurate data acquisition.

The RF chamber, with its quiet zone, calibrated antennas, and the reference positioner, plays a critical part in the test solution. NI has specified these elements to provide excellent RF performance, fast and smooth movement, and reliable and very repeatable positioning accuracy without compromising positioning flexibility for various types of DUTs.

## V. Transitioning to High-Volume 5G Device Production

Many of the technical characterization and validation challenges of wider front-end modules, PAs, and other RFICs for 5G New Radio follow these devices from the lab to the production floor. Working with high-bandwidth signals in FR1 and FR2, covering more bands, and testing

beamforming devices with no access to RF connectors represent more great challenges for engineers. 5G commercial success requires lower test times per DUT— just a few seconds—higher yields, and reduced capital and operational expenses. Engineers are looking for practical ways to implement low-cost, efficient, and high-throughput production 5G device test setups.

Although the need to test devices OTA has existed for decades, primarily in defense applications such as phased-array radar, many engineers question the feasibility of traditional test methods that use large anechoic chambers for meeting much larger production goals. Whenever engineers discuss OTA test solutions, RF chambers almost automatically appear as necessary components of the solution. For design characterization, validation, compliance, and conformance tests, a proper RF chamber surely provides a quiet RF environment that ensures that the design meets all performance and regulatory requirements with enough margin and repeatability. However, for volume production, traditional RF chambers can take much of the production floor space, disrupt material handling flows, and multiply capital expenses.

To tackle these problems, OTA-capable IC sockets (small RF enclosures with an integrated antenna) are starting to become commercially available for semiconductor OTA test functionality in a reduced form factor (see Figure 39). Although the measurement antenna is a couple of centimeters away from the DUT, that's enough distance for far-field measurements using the antenna aperture of each antenna element, not the whole array. The relatively small size of the socket also facilitates multisite, parallel tests to increase test throughput while minimizing signal power losses. On the other hand, the small socket must deal with reflections, and it prevents making beamformed measurements for the whole antenna array, which typically has a far-field distance of 40 cm or longer. Consequently, engineers need specific DUT test modes that give them individual access to each element, and the ability to create listable test sequences to reduce software interaction with the DUT and the test instruments, to boost test execution speed.

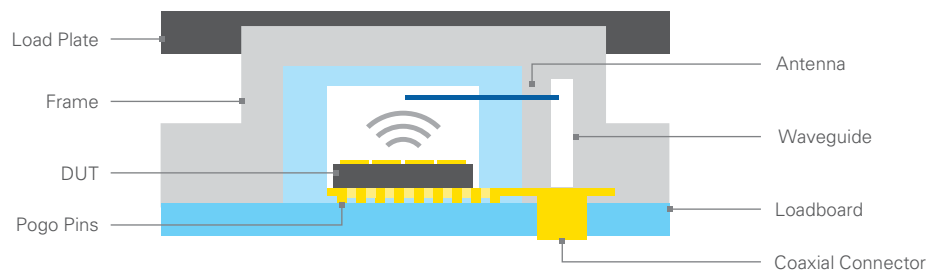

Figure 39. RFIC OTA Test Socket for Multisite Test

Even using small RF enclosures, engineers have the challenge of constrained OTA link budgets for their tests. For example, at 28 GHz, a mere 10 cm distance between the DUT and the antenna translates to more than 30 dB of free space path loss (including the gain of the transmit and receive antennas), as opposed to just about 1 dB on an equal length coax cable. Considering a receiver IP3 measurement, OTA methods would require the test instrument to produce 30 dB higher output power at the transmit antenna in order to achieve the same level of received power at the DUT. This can be a challenge for RF chamber-based OTA configurations, whereas OTA socket-based solutions, at 1.5 cm away, require much less transmitted power.

An alternative OTA test approach is to set up the production test system with longer RF enclosures. The DUT lights up the full antenna array with beamforming functions enabled, rather than each antenna element individually, and looks for aggregate RF performance at key beamforming directions. The test challenge here is to identify the broken or weak connections between the die and package substrate, as well as the quality of the antenna within the package. During initial production ramp, vendors may run full parametric OTA tests, switching to a subset of tests for full volume production.

New test platforms also must address the challenge of having to serve the test needs of today's 5G devices while retaining the ability to expand coverage for tomorrow's more capable designs. For instance, while many manufacturers continue to figure out how best to test devices in the 24 to 52 GHz bands, researchers are pushing the frequency and interoperability boundaries by exploring protocol coexistence in the 57 to 66 GHz band defined for WLAN IEEE 802.11.

### NI Solution

Featuring active beamformer electronics, newer-generation 5G active antenna array devices now have many nonlinear RF components, such as digitally controlled PAs, LNAs, phase shifters, and mixers. New designs incorporate multichannel configurations in a single package. To reach high-throughput volumes, automated production test systems must handle highly parallel multisite testing. NI's modular test platform described in the previous sections for characterization and validation tasks naturally maps to production floor test needs, thanks to its reduced footprint, lower cost, and automation focus. It addresses the needs of the latest 5G NR PHY layer requirements and includes the measurement science and instantaneous bandwidth necessary to create multichannel test systems. These PXI-based test systems can measure wide 5G NR component carriers or carrier-aggregated signals in FR1 with the PXIe-5840 VST, and FR2 with the mmWave VST. Combining dozens of bidirectional RF ports results in 5G-ready test solutions that match the wideband performance of high-end bench instruments while testing many more devices per minute.

For outsourced semiconductor assembly and test companies, it becomes paramount to design for 5G scalability and anticipate nascent semiconductor technologies. The most efficient way to deliver faster test technologies to market with the built-in flexibility to improve or add to the initial test capabilities in the future, and thus avoid rapid obsolescence, is by designing a modular test architecture.

NI integrates all of these capabilities into a single-platform test solution for production-ready, reliable, fast, cost-effective 5G testing while minimizing expenses—and floorspace requirements—to get the most out of manufacturing capability investments. The NI Semiconductor Test System (STS) incorporates the test speed and value of the industry-standard PXI platform into a production-ready ATE that can scale up to meet evolving 5G test requirements and constricting budgets. While big mmWave test boxes designed for the lab continue to increase in size and price, NI puts the power and cost-efficiency of the PXI mmWave VST directly into scalable production ATE. Test engineers can address the demanding mmWave modulated measurements of new kinds of 5G RFICs while meeting the operational needs of 5G semiconductor production environments.

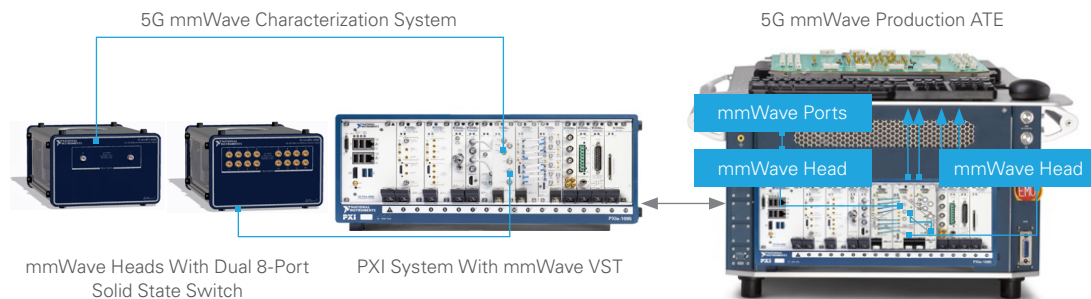

Figure 40. mmWave Production Solution Based on the Semiconductor Test System

Given today's rapid development cycles, flexible and scalable test methodologies are critical for OTA testing. NI continues to collaborate very closely with industry leaders on validation and production OTA solutions using a platform approach composed of highly modular RF instrumentation and software-defined test solutions. This way, engineers can rest assured that their capital expenses can keep pace with the wireless industry's ever-evolving test needs.

## Conclusion

The rapid development of high-bandwidth 5G technologies has introduced significant challenges for testing and measuring new device RF performance. To keep pace with aggressive 5G market demands, researchers and engineers need to rely on faster and more cost-effective test systems that can tackle these challenges. One of the toughest is mmWave OTA test, both in the characterization lab and on the production floor.

Although test and measurement systems must be designed to test current AiP devices, they also must be adaptable to deal with future beamforming and OTA testing requirements. This implies that test systems must have the flexibility to move beyond testing today's devices and anticipate future semiconductor technologies. The NI platform of modular hardware and flexible software empowers engineers to take advantage of new instrument features to speed up and streamline the characterization, validation, and production test of 5G devices.

## References

- <sup>1</sup> Qi, Y. et al., "5G Over-the-Air Measurement Challenges: Overview," *IEEE Transactions on Electromagnetic Compatibility*, vol. 59, no. 6 (December 2017): 1661-1670.
- <sup>2</sup> Schmidt, C.H., M.M. Leibfritz, and T.F. Eibert, "Fully Probe-Corrected Near-Field Far-Field Transformation Employing Plane Wave Expansion and Diagonal Translation Operators," *IEEE Transactions on Antennas and Propagation*, vol. 56, no. 3 (March 2008).
- <sup>3</sup> Derat, B., C. Rowell, and A. Tankielun, "Promises of Near-Field Software and Hardware Transformations for 5G OTA," *2018 IEEE Conference on Antenna Measurements & Applications (2018)*: 1-4.
- <sup>4</sup> 3GPP TR 38.810, Section 5.2.
- <sup>5</sup> 3GPP TR 38.810, Section 5.2.3.3.5.
- <sup>6</sup> 3GPP TR 38.810, Annex G 2.3.
- <sup>7</sup> 3GPP TR 38.810, Annex G 2.3.
- <sup>8</sup> ETSI TR 102 273-1-2, v 1.2.1 (2001-12), Annexes A.5 E.
- <sup>9</sup> 3GPP TR 38.903, v 15.2.0 (2019-3) §B.2.1.2, R4-1800850.